

SPECIFICATION FOR APPROVAL

Product Type: Character Type STN Dot Matrix
LCD Module

Part No.: SD-C2004A-YFDN-DYNC

Customer: _____

Customer Part No.: _____

Date: _____

APPOVED SIGNATURES

SANTTECH	Customer

SANTTECH DISPLAY CO.,LTD

- 1 . REVISION RECORD
- 2. GENERAL SPECIFICATION**
3. OUTLINE DEMENSION:
4. BLOCK DIAGRAM
- 5.ABSOLUTE MAXIMUM RATINGS
- 6.ELECTRICAL CHARACTERISTICS
- 7.ABSOLUTE MAXIMUM RATINGS FOR LED BACKLIGHT
- 8.PIN ASSIGNMENT
- 9.MPU INTERFACE
- 10.REFLECTOR OF SCREEN AND DIPLAY RAM
- 11.DISPLAY CONTROL INSTRUCTION
- 12.OPTICAL CHARACTERISTICS
- 13.POWER SUPPLY SCHEMATICS
- 14.APPLICATION EXAMPLE
- 15. PRECAUTION FOR USING LCM**

1 . REVISION RECORD

REV	DATE	PAGES	DESCRIPTION
2.0	2025-05-07	5	Height from PCB to Bezel 8.8-→9.5(mm)

2.GENERAL SPECIFICATION

Interface with 4-bit or 8-bit MPU (directly connected M6800 serial MPU)

Display Specification

Display Character: 20 character X 4 line Character Font:5X7dors+cursor

Display color-Display background color : STN, Black-Yellow

Polarize mode: positive, Transflective

Viewing angle: 6:00

Display duty: 1/16 Driving bias: 1/5

Character Generator ROM (CGROM): 8320 bits (192 characterX5X7 dots) &(32 characterX5X10 dots)

Character Generator RAM (CGRAM): 64X8 bits (8 charactersX5X8 dots)

Display Data RAM (DDRAM) :80X8 bits (80 characters max)

Mechanical characteristics (Unit: mm)

External dimension: 98.0X60.0X13.5

View area: 76.0X25.2

Character font: 5X7 dots + cursor

Character size: 2.95X4.75

Dots size:0.55X0.55

Character pitch: 3.55X5.35

Weight: 60g

POWER: +5V

3. OUTLINE DEMENSION:

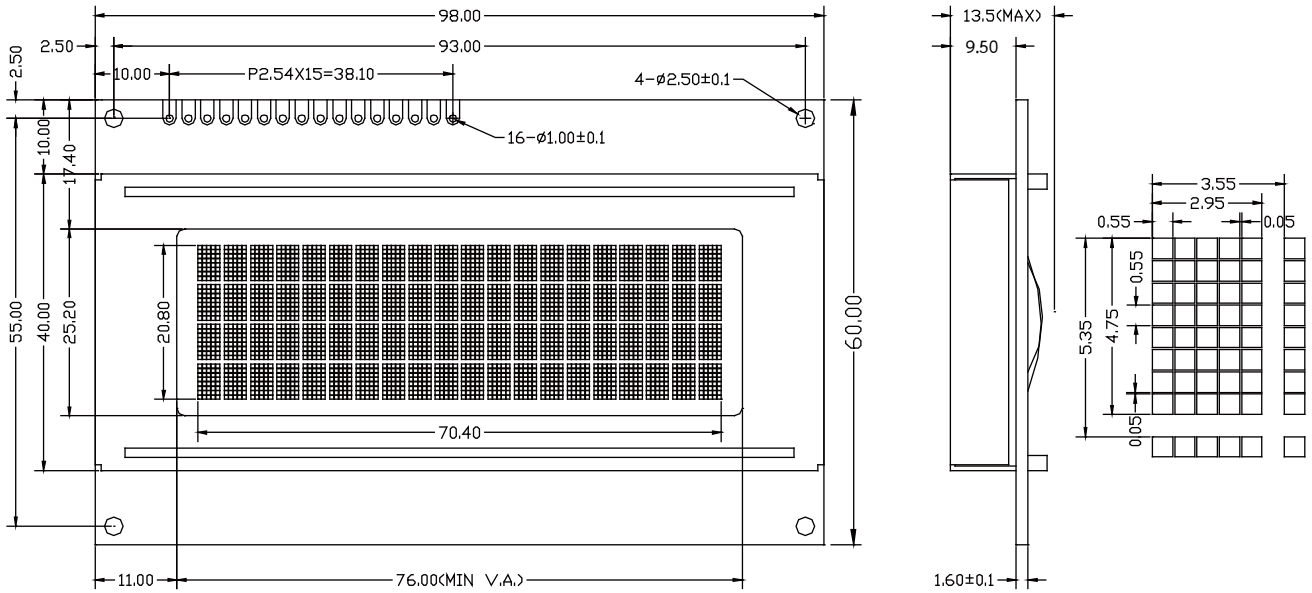

4. BLOCK DIAGRAM:

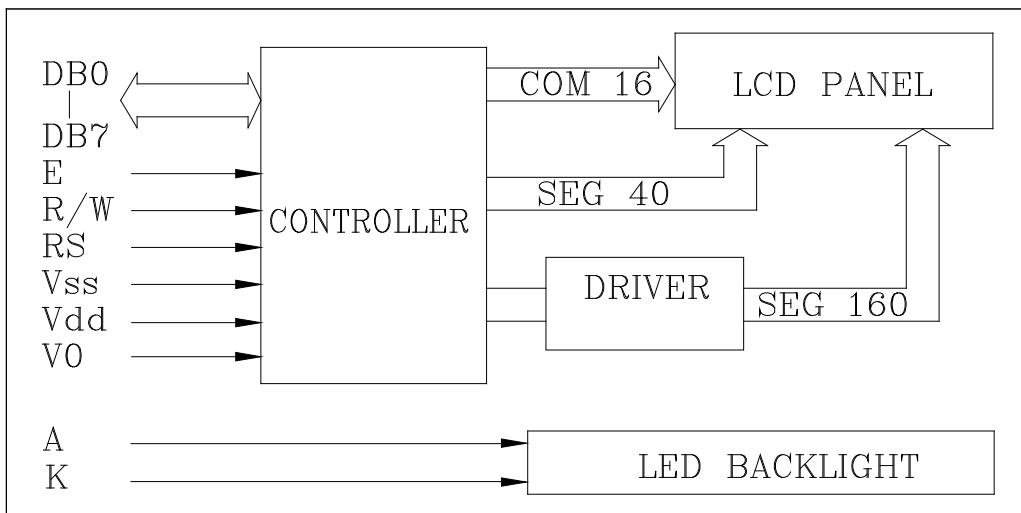

5. Absolute Maximum Ratings

Item	Symbol	Condition	Standard Value		Unit
			Min	Max	
Supply Voltage for logic	Vdd		-0.3	7.0	V
Supply Voltage for LCD	Vlcd		Vdd-10.0	Vdd+0.3	V
Input Voltage	Vi		-0.3	Vdd+0.3	V
Operating Temperature(T)	Top	-	0	50	°C
Storage Temperature(T)	Tstg	-	-10	60	°C

6. ELECTRICAL SPECIFICATIONS(Ta=25⁰C, Vdd=5.0V)

Item	Symbol	Condition	Standard Value			Unit
			Min	Type	Max	
Supply Voltage for logic	Vdd-GND	-	4.5	5.0	5.5	V
Supply Current for logic	Idd	Vdd=5V	-	1.0	-	mA
Driving Current for LCD	Iee		-	0.6	-	mA
Driving Voltage for LCD	Vlcd		4.4	4.7	5.0	V
Input Voltage H level	Vih		2.2	-	Vdd	V
Input Voltage L level	Vil		-0.3	-	0.6	V
Output Voltage H	Voh		Ioh=-0.205mA	2.4	-	-
Output Voltage L	Vol	Io1=1.2mA	-	-	0.4	V

7. Absolute Maximum Ratings For Bottom LED Backlight

Parameter	Symbol	Test condition	Min	Type	Max	Unit
LED Forward Consumption Current	If	Ta=25 ⁰ C	-	120	180	mA
LED Allowable Dissipation	Pa	Vf=4.2V	-	384	630	mW

8. Pin assignment

Pin NO.	Symbol	Function		Remark
1	Vss	Power Supply	0V	
2	Vdd		+5V	
3	Vo		For LCD	Variable
4	RS	Register Select (H: Data L: Instruction)		
5	R/W	L: MPU to LCM H: LCM to MPU		
6	E	Enable		
7	DB0	Data Bit 0		
8	DB1	Data Bit 1		
9	DB2	Data Bit 2		
10	DB3	Data Bit 3		
11	DB4	Data Bit 4		
12	DB5	Data Bit 5		
13	DB6	Data Bit 6		
14	DB7	Data Bit 7		
15	A	Anode of LED Unit		
16	K	Cathode of LED Unit		

9. MPU Interface (Vdd=4.5V~5.5V, Ta=-30~+85°C)

Mode	Characteristic	Symbol	Min.	Type	Max	Unit
Write Mode	E Cycle Time	t_c	500	-	-	ns
	E Rise/Fall Time	t_{r,t_f}	-	-	20	
	E Pulse Width (High, Low)	t_{pW}	230	-	-	
	R/W and RS Setup time	t_{sp1}	40	-	-	
	R/W and RS Hold Time	t_{hd1}	10	-	-	
	Data Setup Time	t_{sp2}	80	-	-	
	Data Hold Time	t_{hd2}	10	-	-	
Read Mode	E Cycle Time	t_c	500	-	-	ns
	E Rise/Fall Time	t_{r,t_f}	-	-	20	
	E Pulse Width(High, Low)	t_{pW}	230	-	-	
	R/W and RS Setup Time	t_{sp1}	40	-	-	
	R/W and RS Hold Time	t_{hd2}	10	-	-	
	Data Output Delay Time	t_d	-	-	120	
	Data Hold Time	t_{hd2}	5	-	-	

IC Specifications

See The Reference of Sunplus Data Book-----SPLC780D

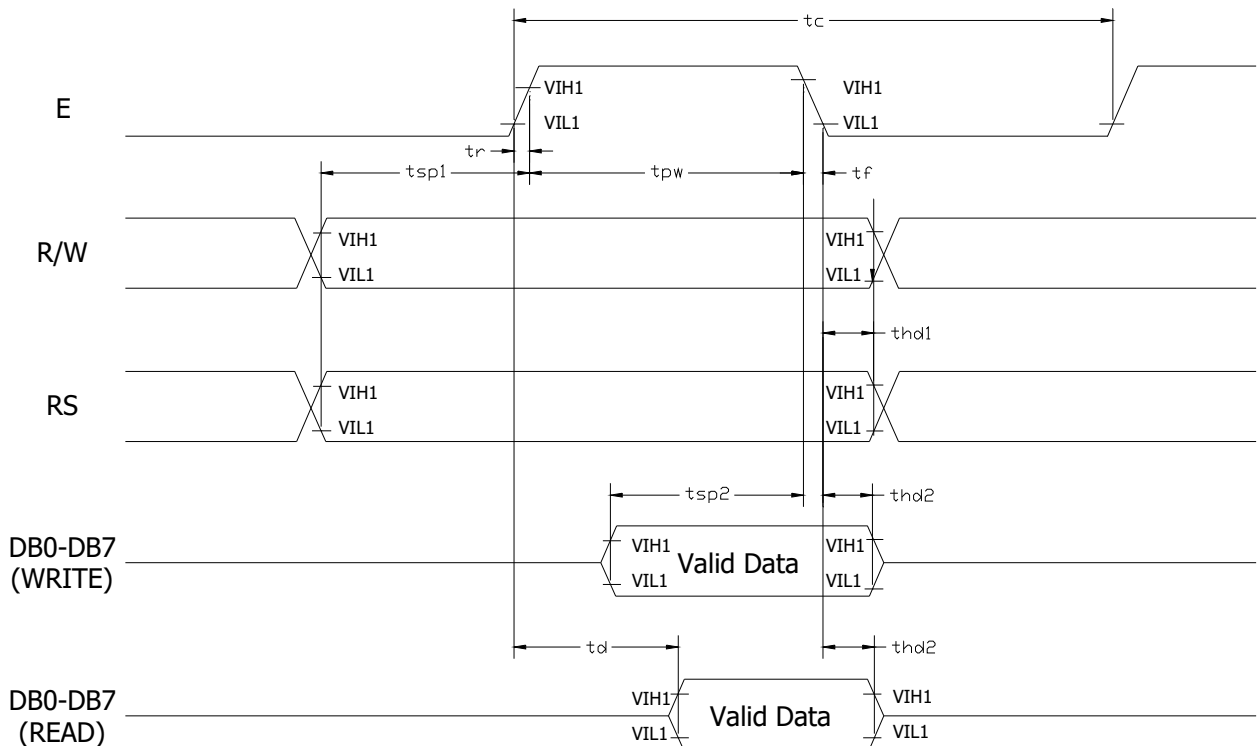
Timing diagram

10. Reflector of Screen and Display RAM

Display position	1-1	1-2	1-3	1-4	1-5	1-6	1-7	1-8	1-9	1-10
DDRAM address	00	01	02	03	04	05	06	07	08	09
Display position	1-11	1-12	1-13	1-14	1-15	1-16	1-17	1-18	1-19	1-20
DDRAM address	0A	0B	0C	0D	0E	0F	10	11	12	13
Display position	3-1	3-2	3-3	3-4	3-5	3-6	3-7	3-8	3-9	3-10
DDRAM address	14	15	16	17	18	19	1A	1B	1C	1D
Display position	3-11	3-12	3-13	3-14	3-15	3-16	3-17	3-18	3-19	3-20
DDRAM address	1E	1F	20	21	22	23	24	25	26	27
Display position	2-1	2-2	2-3	2-4	2-5	2-6	2-7	2-8	2-9	2-10
DDRAM address	40	41	42	43	44	45	46	47	48	49
Display position	2-11	2-12	2-13	2-14	2-15	2-16	2-17	2-18	2-19	2-20
DDRAM address	4A	4B	4C	4D	4E	4F	50	51	52	53
Display position	4-1	4-2	4-3	4-4	4-5	4-6	4-7	4-8	4-9	4-10
DDRAM address	54	55	56	57	58	59	5A	5B	5C	5D
Display position	4-11	4-12	4-13	4-14	4-15	4-16	4-17	4-18	4-19	4-20
DDRAM address	5E	5F	60	61	62	63	64	65	66	67

-1 means first character of line 1 on screen

11. DISPLAY CONTROL INSTRUCTION

Instruction	Instruction Code										Description	ExecutionTime(f osc=270kHz)
	RS	R/W	DB7	DB6	DB5	DB4	DB3	DB2	DB1	DB0		
Clear Display	0	0	0	0	0	0	0	0	0	1	Write "20H" to DDRAM set DDRAM address to "00H" from AC	1.52ms
Return Home	0	0	0	0	0	0	0	0	1	-	Set DDRAM address to "00H" from AC and return cursor to its original position if shifted. The contents of DDRAM are not changed	1.52ms
Entry Mode Set	0	0	0	0	0	0	0	1	I/D	SH	Assign cursor moving direction and enable the shift of entire display	38 μ s
Display ON/OFF Control	0	0	0	0	0	0	1	D	C	B	Set display (D) cursor(C) and blinking of cursor(B) on/off	38 μ s
Cursor or Display Shift	0	0	0	0	0	1	S/C	R/L	-	-	Set cursor moving and display shift control bit, and the direction, without changing DDRAM data	38 μ s
Function Set	0	0	0	0	1	DL	N	F	-	-	Set interface data length of display line (N: 2line/1line)and, display font type F:5X11dots/5X8dots	38 μ s
Set CGRAM Address	0	0	0	1	AC5	AC4	AC3	AC2	AC1	AC0	Set CGRAM address in address counter	38 μ s
Set DDRAM Address	0	0	1	AC6	AC5	AC4	AC3	AC2	AC1	AC0	Set DDRAM address in address counter	38 μ s
Read Busy Flag and Address	0	1	BF	AC6	AC5	AC4	AC3	AC2	AC1	AC0	Whether during internal operation or not can be known by reading BF The contents of address counter of address counter can also be read	0 μ s
Write Data to RAM	1	0	D7	D6	D5	D4	D3	D2	D1	D0	Write data into internal RAM (DDRAM/CGRAM)	38 μ s
Read data from RAM	1	1	D7	D6	D5	D4	D3	D2	D1	D0	Read data from internal RAM (DDRAM/CGRAM)	38 μ s

Instruction Description

Clear Display

RS	R/W	DB7	DB6	DB5	DB4	DB3	DB2	DB1	DB0
0	0	0	0	0	0	0	0	0	1

Clear all the display data by writing "20H" (space code) to all DDRAM address, and set DDRAM address to "00H" into AC(address counter).Return cursor to the original status, namely, bring the cursor to the left edge on the first line of the display. Make the entry mode increment(I/D=HIGH)

Return Home

RS	R/W	DB7	DB6	DB5	DB4	DB3	DB2	DB1	DB0
0	0	0	0	0	0	0	0	1	-

Set DDRAM address to "00H" into the address counter. Return cursor to its original site and return display to its original status, if shifted. Contents of DDRAM do not change.

Entry Mode Set

RS	R/W	DB7	DB6	DB5	DB4	DB3	DB2	DB1	DB0
0	0	0	0	0	0	0	1	I/D	SH

Set the moving direction of cursor and display.

I/D: Increment/decrement of DDRAM address (cursor or blink)

When I/D=High, cursor/blink moves to right and DDRAM address is increased by 1.

When I/D=low, cursor/blink moves to left and DDRAM address is decreased by 1.

*CGRAM operates the same as DDRAM, when reading from or writing to CGRAM.

SH: Shift of entire display

When DDRAM read (CGRAM read/write) operation or SH="Low", shifting of entire display is not performed. If SH=High, and DDRAM write operation, shift of entire display is performed according to I/D value(I/D=High, shift left, I/D=Low, shift right).

Display ON/OFF Control

RS	R/W	DB7	DB6	DB5	DB4	DB3	DB2	DB1	DB0
0	0	0	0	0	0	1	D	C	B

D: Display ON/OFF control bit

When D=High, entire display is turned on.

When D=Low, display is turned off, but display data remains in DDRAM.

C: Cursor ON/OFF control bit

When C=High, cursor is turned on.

When C=Low, cursor is disappeared in current display, but I/D register preserves its data.

B: Cursor Blink ON/OFF control bit

When B=High, cursor blink is on ,which performs alternately between all the high data and display characters at the cursor position. When B=Low, Blink is off.

Cursor or Display Shift

RS	R/W	DB7	DB6	DB5	DB4	DB3	DB2	DB1	DB0
0	0	0	0	0	1	S/C	R/L	-	-

Shifting of right/left cursor position or display without writing or reading of display data. This instruction is used to correct or search display data. During 2-line mode display ,cursor moves to the 2nd line after the 40th digit of the 1st line. Note that display shift is performed simultaneously in all the lines. When displayed data is shifted repeatedly, each line is shifted individually. When display shift is performed, the contents of the address counter are not changed.

S/C	R/L	Operation
0	0	Shift cursor to the left, AC is decreased by 1
0	1	Shift cursor to the right, AC is increased by 1
1	0	Shift all the display to the left, Cursor moves according to the display
1	1	Shift all the display to the right, cursor moves according to the display

Function set

RS	R/W	DB7	DB6	DB5	DB4	DB3	DB2	DB1	DB0
0	0	0	0	1	DL	N	F	-	-

DL: Interface data length control bit

When DL=High, it means 8-bit bus mode with MPU.

When DL=Low, it means 4-bit bus mode with MPU. When 4-bit bus mode, it needs to transfer 4-bit data twice.

N: Display line number control bit

When N=Low, 1-line display mode is set.

When N=High, 2-line display mode is set.

F: Display font type control bit

When F=Low, 5X8 dots format display mode is set .

When F=High, 5X11 dots format display mode.

Set CGRAM Address

RS	R/W	DB7	DB6	DB5	DB4	DB3	DB2	DB1	DB0
0	0	0	1	AC5	AC4	AC3	AC2	AC1	AC0

Set CGRAM address to AC. This instruction makes CGRAM data available from MPU.

Set DDRAM Address

RS	R/W	DB7	DB6	DB5	DB4	DB3	DB2	DB1	DB0
0	0	1	AC6	AC5	AC4	AC3	AC2	AC1	AC0

Set DDRAM address to AC. This instruction makes DDRAM data available from MPU. When 1-line display mode (N=Low), DDRAM address is from “00H” to “4FH” In 2-line display mode (N=High), DDRAM address in the 1st line is from “00H” to “27H” and DDRAM address in the 2nd line is from “40H” to “67H”.

Read Busy Flag & Address

RS	R/W	DB7	DB6	DB5	DB4	DB3	DB2	DB1	DB0
0	1	BF	AC6	AC5	AC4	AC3	AC2	AC1	AC0

This instruction shows whether IC is in internal operation or not. If BF is high internal operation is in progress and should wait until BF is to be Low, which by then the next instruction can be performed. In this instruction you can also read the value of the address counter.

Write data to RAM

RS	R/W	DB7	DB6	DB5	DB4	DB3	DB2	DB1	DB0
1	0	D7	D6	D5	D4	D3	D2	D1	D0

Write binary 8-bit data to DDRAM/CGRAM. The selection of RAM from DDRAM, and CGRAM, is set by the previous address set instruction (DDRAM address set, CGRAM address set). RAM set instruction can also determine the AC direction to RAM. After write operation, the address is automatically increased/decreased by 1, according to the entry mode.

Read data from RAM

RS	R/W	DB7	DB6	DB5	DB4	DB3	DB2	DB1	DB0
1	1	D7	D6	D5	D4	D3	D2	D1	D0

Read binary 8-bit data from DDRAM/CGRAM. The selection of RAM is set by the previous address set instruction. If the address set instruction of RAM is not performed before this instruction, the data that has been read first is invalid, as the direction of AC is not yet determined. If RAM data is read several times without RAM address instructions set before read operation, the correct RAM data can be obtained from the second. But the first data would be incorrect, as there is no time margin to transfer RAM data. In case of DDRAM read operation, cursor shift instruction plays the same role as DDRAM address set instruction, it also transfers RAM data to output data register. After read operation, address counter is automatically increased/decreased by 1 according to the entry mode.

After CGRAM read operation, display shift may not be executed correctly.

Note:

In case of RAM write operation, AC is increased/decreased by 1 as in read operation. At this time, AC

indicates the next address position, but only the previous data can be read by the read instruction.

Relationship between Character Code and CGRAM

Character code	CGRAM Address	CGRAM Data	Pattern number
D7 D6 D5 D4 D3 D2 D1 D0	A5 A4 A3 A2 A1 A0	P7 P6 P5 P4 P3 P2 P1 P0	
0 0 0 0 x 0 0 0	0 0 0 0 0 0 0 0 1 0 1 0 0 1 1 1 0 0 1 0 1 1 1 0 1 1 1	x x x 0 1 1 1 0 x x x 1 0 0 0 0 x x x 1 0 0 0 0 x x x 0 1 1 1 0 x x x 0 0 0 0 1 x x x 0 0 0 0 1 x x x 0 1 1 1 0 x x x 0 0 0 0 0	Pattern1
.....
0 0 0 0 x 1 1 1	0 0 0 0 0 0 0 0 1 0 1 0 0 1 1 1 0 0 1 0 1 1 1 0 1 1 1	x x x 0 1 1 1 0 x x x 1 0 0 0 1 x x x 1 0 0 0 1 x x x 1 1 1 1 1 x x x 1 0 0 0 1 x x x 1 0 0 0 1 x x x 1 0 0 0 1 x x x 0 0 0 0 0	Pattern8

Display Data RAM(DDRAM)

DDRAM stores display data of maximum 80x8bits (80 characters). DDRAM address is set in the address counter (AC) as a hexadecimal number

MSB						LSB
AC6	AC5	AC4	AC3	AC2	AC1	AC0

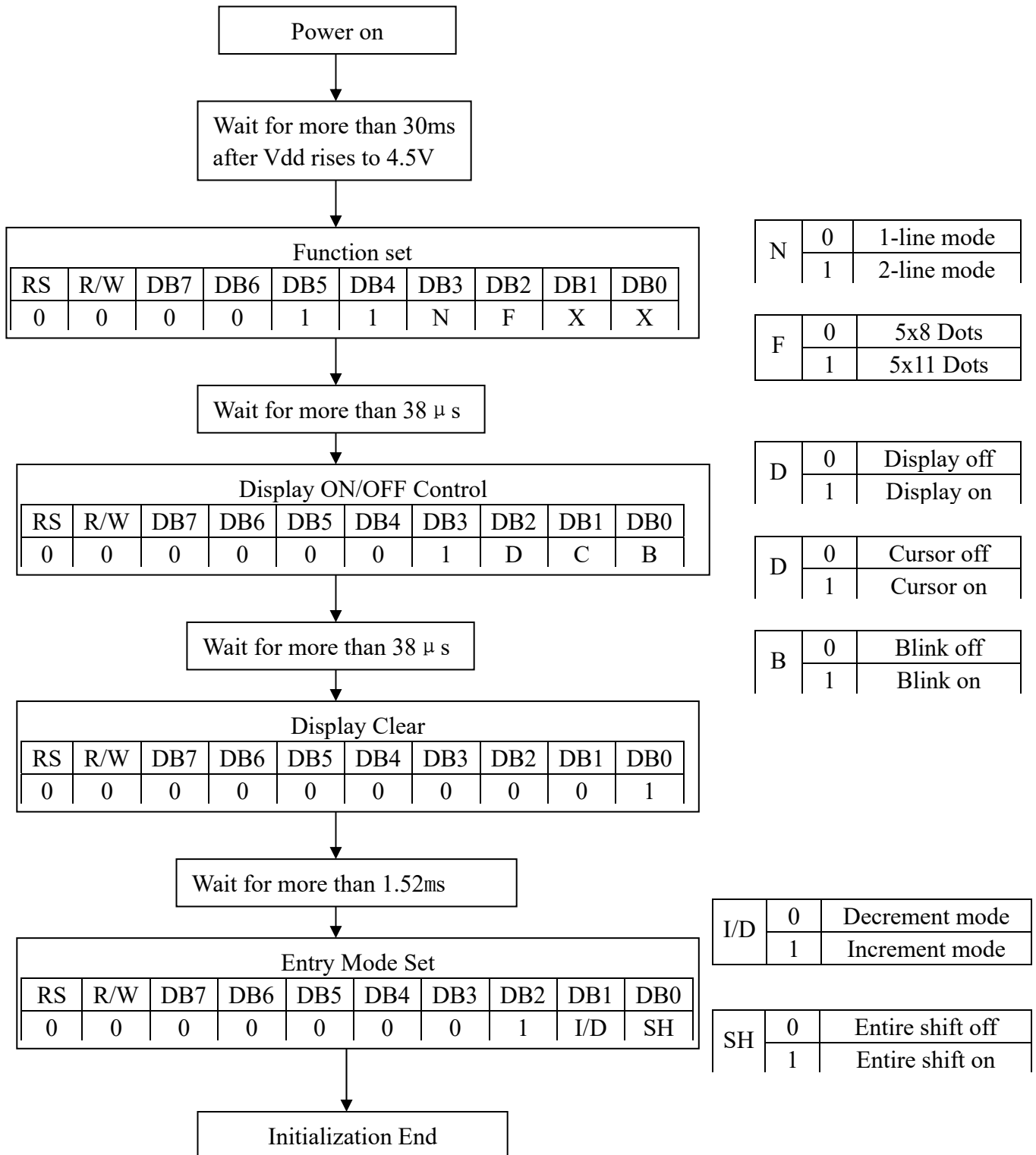
Initializing Flowchart (Condition: fosc=270KHZ)

12.OPTICAL CHARACTERISTICS:

ITEM	SYMBOL	CONDITION	MIN.	TYP.	MAX.	UNIT	REF.
Contrast	CR	25°C, Vdd=5V, θ =0, Ø=0	--	12	--		(2)
Rise Time	Tr	25°C, Vdd=5V, θ =0, Ø=0	--	160	240	ms	(3)
Fall Time	Tf	25°C, Vdd=5V, θ =0, Ø=0	--	100	150	ms	(3)
Viewing Angle	θ 1- θ 2	25°C	--	--	60	DEG	(1)
	Ø1, Ø2		-40	--	40		

(1)Definition of viewing Angle:

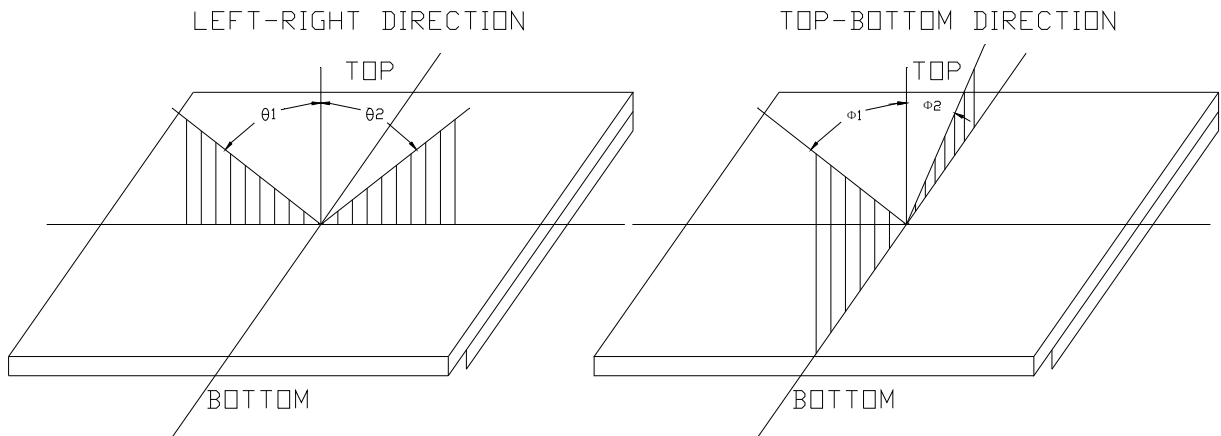

(2)Definition of Contrast Ratio:

$$\text{Contrast Ratio} = \frac{\text{Brightness of non-selected condition}}{\text{Brightness of selected condition}}$$

Test condition: standard A light source

(3)Response Time:

Response time is measured as the shortest period of possible between the change in state of an LCD segments as demonstrated below:

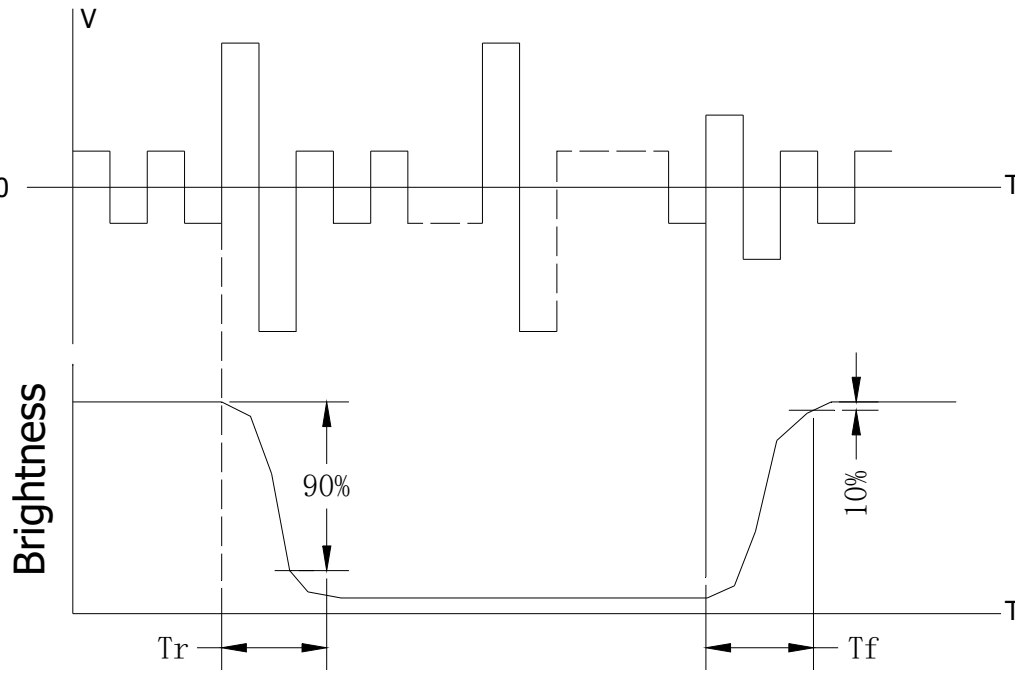

13. POWER SUPPLY SCHEMATICS

For Single Source

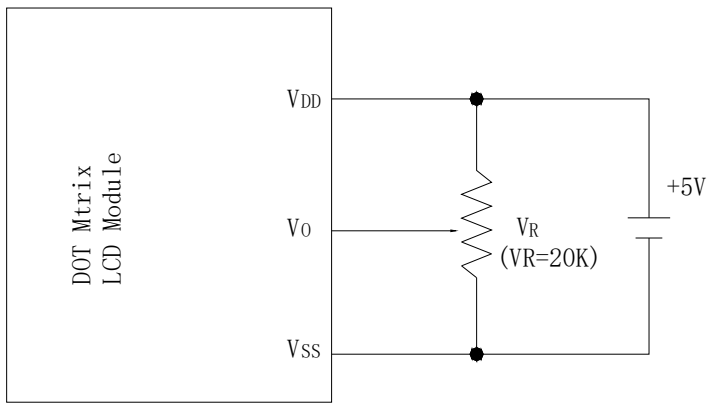

For Double Source

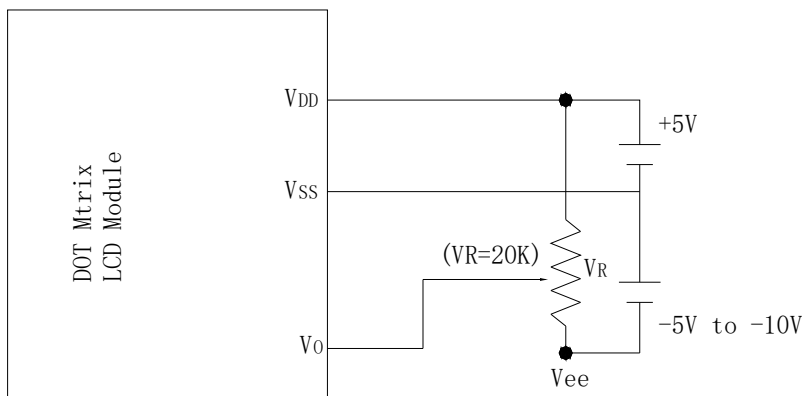

14. APPLICATION EXAMPLE

Application Circuit

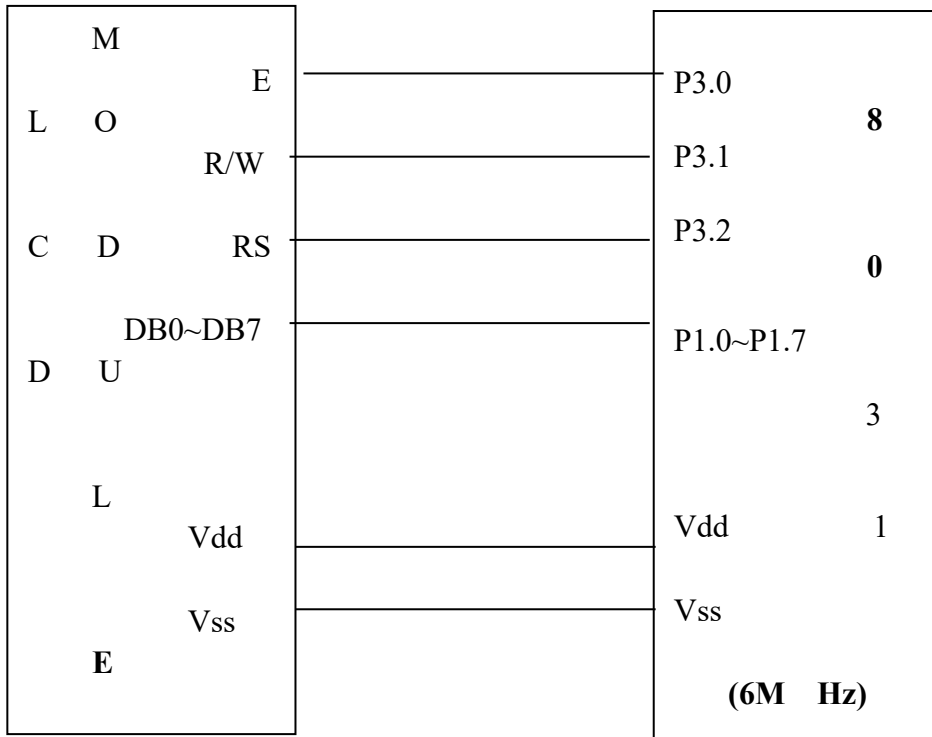

Application Flowchart

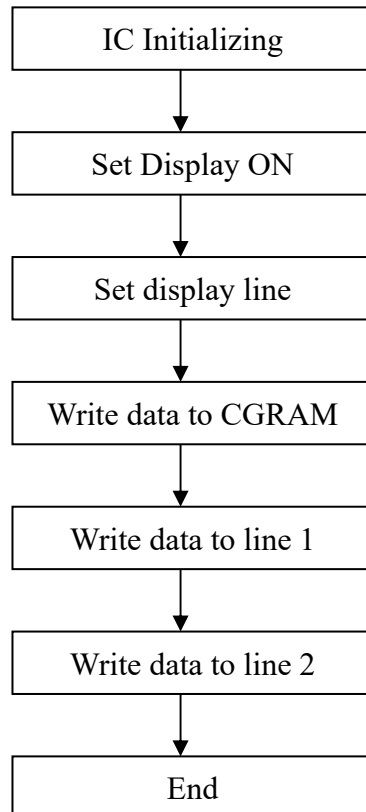

Upper 4bit Lower 4bit	LLLL	LLLH	LLHL	LLHH	LHLL	LHLH	LHHH	HLLL	HLLH	HHLH	HLHH	HLLL	HLLH	HHLH	HHHL	HHHH
LLLL				00P'P												
LLLH		!	1	A0a9												
LLHL		"	2	Bbr												
LLHH		#	3	Scs												
LHLL		\$	4	Dtd												
LHLH		%	5	Eeu												
LHHH		&	6	FfU												
HLLL		'	7	Ggw												
HLLH		(8	Hhx												
HHLH)	9	IYiy												
HLHL		*	:	Jzjz												
HLHH		+	<	KkK												
HHLL		,	>	L羊ll												
HHLH		-	=	MmN												
HHHL		.	>	NnO												
HHHH		/	0	L0e												

15. PRECAUTION FOR USING LCM

1. Liquid Crystal Display (LCD)

LCD is made up of glass, organic sealant, organic fluid, and polymer based polarizers. The following precautions should be taken when handling,

- (1). Keep the temperature within range of use and storage. Excessive temperature and humidity could cause polarization degradation, polarizer peel off or bubble.
- (2). Do not contact the exposed polarizers with anything harder than an HB pencil lead. To clean dust off the display surface. Wipe gently with cotton. Chamois or other soft material soaked in petroleum benzine.
- (3). Wipe off saliva or water drops immediately. Contact with water over a long period of time may cause polarizer deformation or color fading, while an active LCD with water condensation on its surface will cause corrosion of ITO electrodes.
- (4). Glass can be easily chipped or cracked from rough handling, especially at corners and edges.
- (5). Do not drive LCD with DC voltage.

2. Liquid Crystal Display Modules

2.1 Mechanical Considerations

LCM are assembled and adjusted with a high degree of precision. Avoid excessive shocks and do not make any alterations or modifications. The following should be noted.

- (1). Do not tamper in any way with the tabs on the metal frame.
- (2). Do not modify the PCB by drilling extra holes, changing its outline, moving its components or modifying its pattern.
- (3). Do not touch the elastomer connector, especially insert an backlight panel (for example, EL).
- (4). When mounting a LCM make sure that the PCB is not under any stress such as bending or twisting. Elastomer contacts are very delicate and missing pixels could result from slight dislocation of any of the elements.
- (5). Avoid pressing on the metal bezel, otherwise the elastomer connector could be deformed and lose contact, resulting in missing pixels.

2.2. Static Electricity

LCM contains CMOS LSI's and the same precaution for such devices should apply, namely

- (1). The operator should be grounded whenever he/she comes into contact with the module. Never touch any of the conductive parts such as the LSI pads, the copper leads on the PCB and the interface terminals with any parts of the human body.
- (2). The modules should be kept in antistatic bags or other containers resistant to static for storage.
- (3). Only properly grounded soldering irons should be used.
- (4). If an electric screwdriver is used, it should be well grounded and shielded from commutator sparks.
- (5). The normal static prevention measures should be observed for work clothes and working benches; for the latter conductive (rubber) mat is recommended.
- (6). Since dry air is inductive to static, a relative humidity of 50-60% is recommended.

2.3. Soldering

- (1). Solder only to the I/O terminals.
- (2). Use only soldering irons with proper grounding and no leakage.
- (3). Soldering temperature: $280\text{ }^{\circ}\text{C} \pm 10^{\circ}\text{C}$
- (4). Soldering time: 3 to 4 sec.
- (5). Use eutectic solder with resin flux fill.
- (6). If flux is used, the LCD surface should be covered to avoid flux spatters. Flux residue should be removed afterwards.

2.4. Operation

- (1). The viewing angle can be adjusted by varying the LCD driving voltage V_0 .
- (2). Driving voltage should be kept within specified range; excess voltage shortens display life.
- (3). Response time increases with decrease in temperature.
- (4). Display may turn black or dark blue at temperatures above its operational range; this is (however not pressing on the viewing area) may cause the segments to appear "fractured".

(5). Mechanical disturbance during operation (such as pressing on the viewing area) may cause the segments to appear “fractured”.

2.5. Storage

If any fluid leaks out of a damaged glass cell, wash off any human part that comes into contact with soap and water. Never swallow the fluid. The toxicity is extremely low but caution should be exercised at all the time.

2.6. Limited Warranty

Unless otherwise agreed between SANTTECH and customer, SANTTECH will repair or repair any of its LCD and IC, which is found to be defective electrically and visually when inspected in accordance with SANTTECH acceptance standards, for a period on one year from data of shipment. Confirmation of such date shall be based on freight documents. The warranty liability of SANTTECH is limited to repair and/or replacement on the terms set forth above. SANTTECH will not responsible for any subsequent or consequential events.