

SPECIFICATION FOR APPROVAL

Product Type: Graphic Type STN Dot Matrix
LCD Module

Part No.: SD-G12232A-YFDN-DYWC

Customer: _____

Customer Part No.: _____

Date: _____

APPROVED SIGNATURES

SANTECH	Customer

SANTECH DISPLAY CO.,LTD

- 1 . REVISION RECORD**
- 2. GENERAL SPECIFICATION**
- 3. OUTLINE DEMENSION:**
- 4. BLOCK DIAGRAM**
- 5. ABSOLUTE MAXIMUM RATINGS**
- 6. ELECTRICAL CHARACTERISTICS**
- 7. ABSOLUTE MAXIMUM RATINGS FOR LED BACKLIGHT**
- 8. PIN ASSIGNMENT**
- 9. MPU INTERFACE**
- 10. REFLECTOR OF SCREEN AND DIPLAY RAM**
- 11. DISPLAY CONTROL INSTRUCTION**
- 12. OPTICAL CHARACTERISTICS**
- 13. POWER SUPPLY SCHEMATICS**
- 14. APPLICATION EXAMPLE**
- 15. PRECAUTION FOR USING LCM**

1 . REVISION RECORD

REV	DATA	PAGES	DESCRIPTION
V1.0	20070320		NEW VER

2. GENERAL SPECIFICATION

122×32 dots display

LCD driver: 1520

Interface with 8-bit MPU (directly connected to M6800serial MPU)

Display specification

Display dot: 122×32

Display type: STN

Display color-Display background color: BLACK-YELLOW/GREEN

Polarizer mode: positive; Transflective

Viewing angle: 6:00

Display RAM: 5120 bits

Mechanical characteristics (Unit: mm)

External dimension:84×44×13.5

View area: 60.0X18.5

Dot size: 0.4X0.4

Dot pitch: 0.44X0.44

Weight: (g)

Power: +5V

3. OUTLINE DEMENSION:

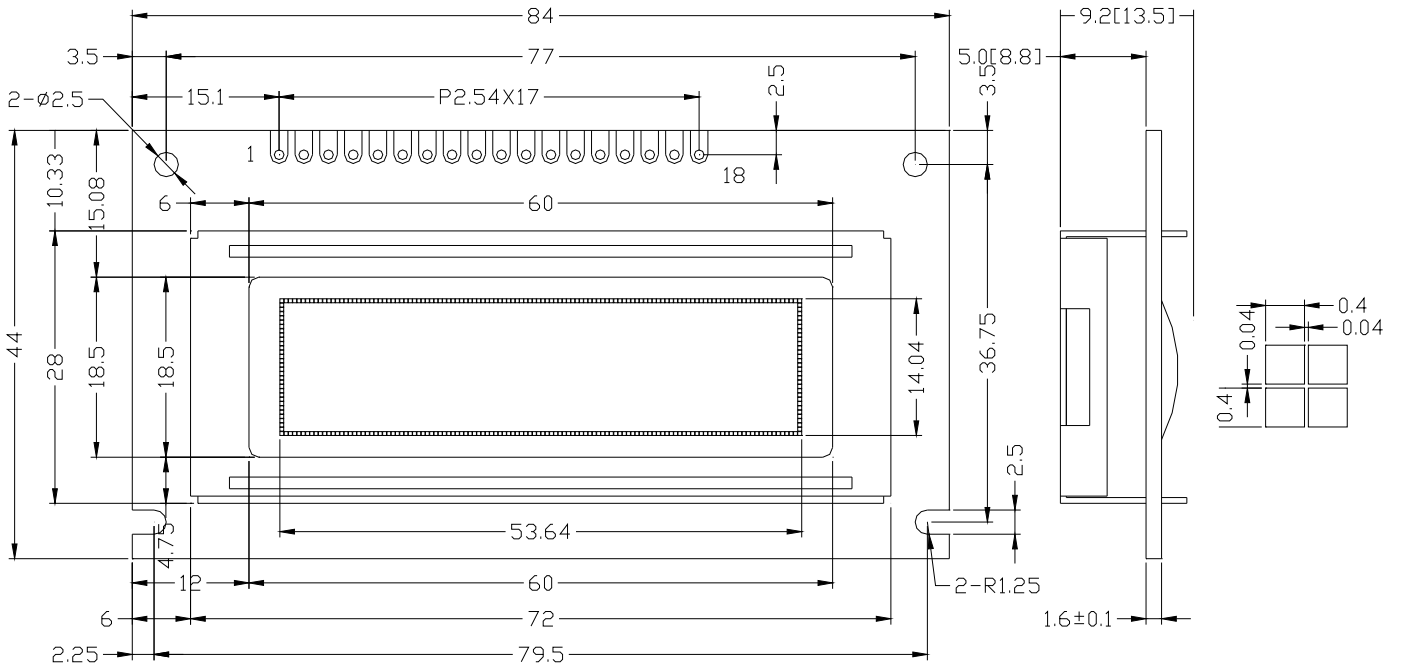

4. BLOCK DIAGRAM:

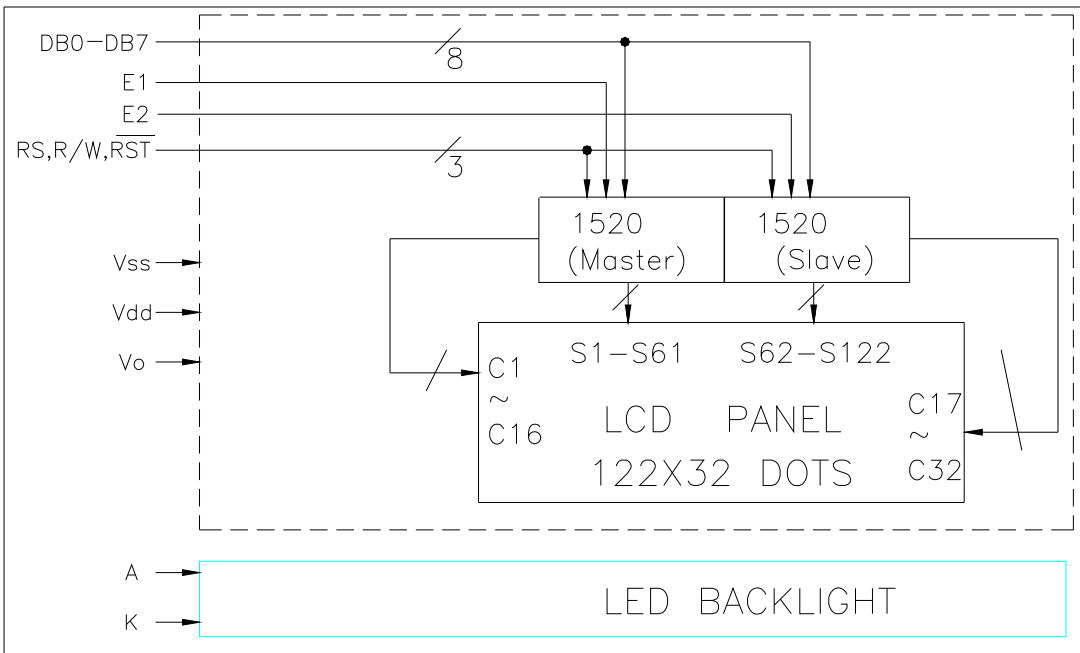

5. Absolute Maximum Ratings

Item	Symbol	Condition	Standard Value		Unit
			Min	Max	
Supply Voltage for logic	Vdd	Ta=25°C	-0.3	7.0	V
Supply Voltage for LCD	Vo		-0.3	Vdd+0.3	V
Input Voltage	Vi		-0.3	Vdd+0.3	V
Operating Temp(T)	Top	-	-10	60	°C
Storage Temp (T)	Tstg	-	-20	70	°C

6. ELECTRICAL SPECIFICATIONS(Ta=25°C,Vdd=5.0V)

Item	Symbol	Condition	Standard Value			Unit
			Min	Type	Max	
Supply Voltage for logic	Vdd-Vss	-	4.5	5.0	5.5	V
Supply Current for logic	Idd	Vdd=5.0	-	150	300	uA
Driving Current for LCD	Io	Vo=4.7	-	100	200	uA
Driving Voltage for LCD	Vdd-Vo	-	-	4.7	-	V
Input Voltage H level	V _{IH}	-	2.0	-	Vdd	V
Input Voltage L level	V _{IL}	-	Vss	-	0.8	V
Output Voltage H level	V _{OH}	I _{OH} =-3.0m A	2.4	-	-	V
Output Voltage L level	V _{OL}	I _{OL} =3.0m A	-	-	0.4	V

7. Absolute Maximum Ratings For Bottom LED Backlight

Parameter	Symbol	Test condition	Min	Type	Max	Unit
LED Forward Consumption Current	I _f	Ta=25°C Vf=4.2V	-	100	150	mA
LED Allowable Dissipation	P _d		-	420	630	mW

8. Pin assignment

Pin NO	Symbol	Function	Remark
1	Vss	Power supply	Variable
2	Vdd		
3	Vo		
4	RS	Register select H: data L: instruction	
5	E1	Read/Write Enable Signal(Slave)	
6	E2	Read/Write Enable Signal(Master)	
7	R/W	Read/write Select Signal	
8-15	DB0~DB7	Data bus	
16	/RES	System Reset	
17	A	Anode of LED Unit	
18	K	Cathode of LED Unit	

9. MPU Interface

Parameter	Symbol	Min	Max	Condition	Unit
Address set up time	t_{Aw6}	40			ns
Address hold time	t_{AH6}	20			ns
System cycle time	t_{CYC6}	2000			ns
E pulse width	Read	200			ns
	Write	160			ns
Data set up time	t_{DS6}	160			ns
Data hold time	t_{DH6}	20		ns	
Access time	t_{ACC6}		180	$C_L=100pF$	ns
Output disable time	t_{OH6}	20	180		ns

***Input signal rise time and fall time are less than 15ns**

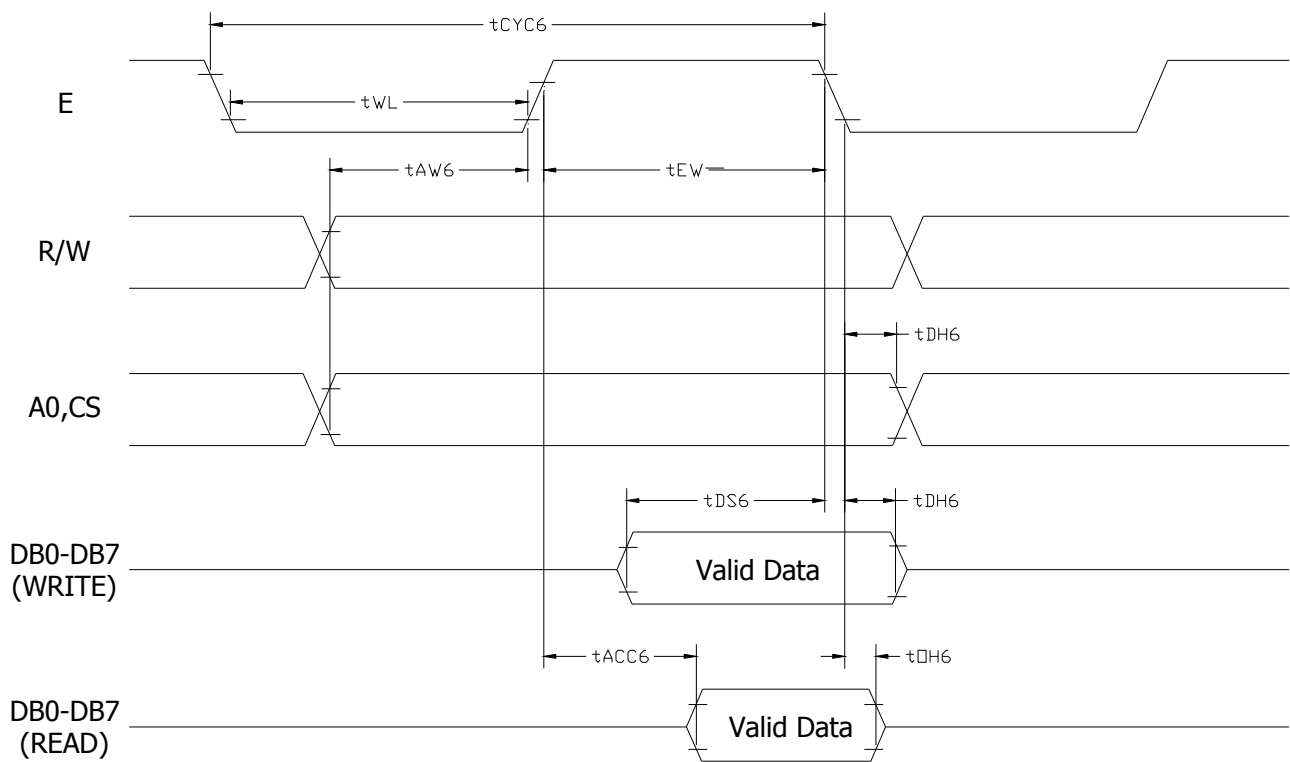

10. Reflector of Screen and Display RAM

Page Address D1,D2	Data	Display Pattern	Line Address	Common Output Example
0,0	D0		00	COM0
	D1		01	COM1
	D2		02	COM2
	D3		03	COM3
	D4		04	COM4
	D5		05	COM5
	D6		06	COM6
	D7		0 Page	07
0,1	D0		08	COM8
	D1		09	COM9
	D2		0A	COM10
	D3		0B	COM11
	D4		0C	COM12
	D5		0D	COM13
	D6		0E	COM14
	D7		1 Page	0F
1,0	D0		10	COM16
	D1		11	COM17
	D2		12	COM18
	D3		13	COM19
	D4		14	COM20
	D5		15	COM21
	D6		16	COM22
	D7		2 Page	17
1,1	D0		18	COM24
	D1		19	COM25
	D2		1A	COM26
	D3		1B	COM27
	D4		1C	COM28
	D5		1D	COM29
	D6		1E	COM30
	D7		3 Page	1F
Column Address	ADC	D0=0 00 01 02 03 04 05 06	4F	
		D0=1 4F 4E 4D 4C 4B 4A 49	00	
Segment Term.		0 1 2 3 4 5 6	60	

11. DISPLAY CONTROL INSTRUCTION

Instruction	A0	R/W	D7	D6	D5	D4	D3	D2	D1	D0	Description	
Display on/off	0	0	1	0	1	0	1	1	1	0/1	Whole display on/off 1:on 0:off	
Display start line	0	0	1	1	0	Display start address(1~31)					Determine the display line correspond to the COM0	
Page address set	0	0	1	0	1	1	1	0	Page (0~3)		Set the page of display data RAM	
Column address set	0	0	0	Column address(0~79)							Set the column address of display data RAM	
Status read	1	0	B U S Y	A D C	O N / O F F	R E S E T	0	0	0	0	BUSY 0:ready 1:working ADC 0:counterclockwise 1:clockwise output ON/OFF 0:disp on 1:disp off RESET 0:normal 1:reset	
Write display data	0	1	Write data								Write data to display RAM	Access the predetermined address of the display RAM
Read display data	1	1	Read data								Read data From display RAM	
ADC select	0	0	1	0	1	0	0	0	0	0/1	Determine the mode reading of the display RAM 0: clockwise output 1: counterclockwise output	
Static drive on/off	0	0	1	0	1	0	0	1	0	0/1	Select the dynamic or static driving 1: static driving 0: dynamic driving	
Duty ratio select	0	0	1	0	1	0	1	0	0	0/1	Select the duty ratio 0: 1/16 1: 1-32	
Read Modify write	0	0	1	1	1	0	0	0	0	0	Increment the column address register when writing but no change when reading	
END	0	0	1	1	1	0	1	1	1	0	Release from the Read Modify Write mode	
Reset	0	0	1	1	1	0	0	0	1	0	Set the display start line register to 1st line , page add . Register to 3	
Power save (dual command)	0 0	0 0	1 1	0 0	1 1	0 0	1 0	1 1	1 0	0 1	Set the power save mode by selecting display off and static driving on	

Instruction Description

(1) Display On/Off

This instruction executes whole display On/Off no relation with the data in the Display Data RAM and internal conditions.

	A0	R/W	D7	D6	D5	D4	D3	D2	D1	D0	
code	0	0	1	0	1	0	1	1	1	1	D

D 0:Display On;
 1:Display Off

when the static driving mode is selected (static drive On) in display Off status, the internal circuits put on the power save mode.

(2) Display Start Line

This instruction set the line address. The selected line in the Display Data RAM correspond to the COM0 Which display at the of LCD panel.

The display area is set automatically from the selected line to the line which increased the number of duty ratio.

Therefore, the smooth scroll for vertical direction by changing the start line address one by one or page switching are available by this instruction.

	A0	R/W	D7	D6	D5	D4	D3	D2	D1	D0
code	0	0	1	1	0	A4	A3	A2	A1	A0

A4	A3	A2	A1	A0	Line Address
0	0	0	0	0	0
				1	1
1	1	1	1	0	1E
1	1	1	1	1	1F

(3) Page Address Set

When MPU access the display Data RAM, the page address corresponded to the row address must be selected.

The access in the display Data RAM is available by setting the page and column address.

The display is on change when the page address is changed.

	A0	R/W	D7	D6	D5	D4	D3	D2	D1	D0
Code	0	0	1	0	1	1	1	1	0	A1 A0

A1	A0	Page
0	0	0
0	1	1
1	0	2
1	1	3

(4) Column Address Set

The instruction set the column address in the Display Data RAM.

When the MPU access the Display Data RAM continuously, the column address increase automatically, therefore, the MPU can access the data only without address setting.

The increment of the column address is stopped by the address of 50H automatically, but the page address is no change even if the column address increase to 50H and stop.

	A0	R/W	D7	D6	D5	D4	D3	D2	D1	D0
code	0	0	0	A6	A5	A4	A3	A2	A1	A0

A6	A5	A4	A3	A2	A1	A0	Column Add
0	0	0	0	0	0	0	0
0	0	0	0	0	0	1	1
1	0	0	1	1	1	0	4E
1	0	0	1	1	1	1	4F

(5) Status Read

This instruction read out the internal status.

	A0	R/W	D7	D6	D5	D4	D3	D2	D1	D0
code	0	1	BUSY	ADC	ON/OFF	RESET	0	0	0	0

BUSY: BUSY=1 indicate the operating or the Reset cycle.

The instruction can be input after the BUSY status change to

ADC: Indicate the output correspondence of column (segment) address and segment driver.

0: Counter clockwise Output (Inverse)

Column Address $79-n$ \longleftrightarrow Segment Driver n

1: Clockwise Output (Normal)

Column Address n \longleftrightarrow Segment Driver n

NO/OFF: Indicate the whole display On/Off status.

0: Whole Display n

1: While Display ff

(Note) The data =On and =Off of Display On/Off status read out is inverted with the Display On/Off instruction data of =On and =Off

RESET: Indicate the initialization period by reset instruction.

(6) Write Display Data

This instruction write the 8-bit data on the data bus into the Display RAM.

The column(segment) address increase automatically when writing, therefore,

The MPU can write the 8-bit data into the Display Data RAM without address setting.

	A0	R/W	D7	D6	D5	D4	D3	D2	D1	D0
61SEG	1	0	Write Data							

(7) Read Display Data

This instruction read out the 8-bit data from Display Data RAM which addressed by the column and page address. In case of the Read Modify Write Mode is off, the column address increase automatically after each read out, therefore, the MPU can read out the 8-bit data from the Display Data RAM continuously without address setting.

	A0	R/W	D7	D6	D5	D4	D3	D2	D1	D0
Code	1	1	Read Data							

(8) ADC Select

This instruction set the correspondence of column address in the Display Data RAM and segment driver out. Therefore, the order of segment output can be changed by the software, and no restriction of the LSI placement against the LCD panel.

	A0	R/W	D7	D6	D5	D4	D3	D2	D1	D0	
Code	0	0	1	0	1	0	0	0	0	0	D

D 0: Clockwise Output (Inverse)
 1: Counter Clockwise Output (Normal)

(9) Static Drive On/Off

This instruction executes the all common output terns on and whole display on obligatory.

	A0	R/W	D7	D6	D5	D4	D3	D2	D1	D0	
Code	0	0	1	0	1	0	0	0	1	0	D

D 0: Static Drive Off (Normal Operation)
 1: Static Drive On (Whole Display Turns On)

When the Display Off mode is selected (Display Off) in Static On status.
 the internal circuits put on the power save mode.

(10)Duty Select

This instruction set the LCD driving duty ratio.

	A0	R/W	D7	D6	D5	D4	D3	D2	D1	D0	
Code	0	0	1	0	1	0	1	0	0	0	D

D 0: 1/16 duty
 1: 1/32 duty

(11) Read Modify Write

After this instruction is executed , the column address increase automatically when Display Data Write Instruction execution, but the address is not changed when the Display Data Read Instruction execution.

This status continues during End instruction .When the End instruction is entered the column address back to the address where Read Modify Write instruction entering. By this function, the load of MPU for example cyclic data writing operation like as cursor blink etc., can be reduced.

	A0	R/W	D7	D6	D5	D4	D3	D2	D1	D0	
Code	0	0	1	1	1	0	0	0	0	0	0

(Note)During the Read Modify Write mode, any instruction except Column Address Set can be executed.

(12) Sequence of cursor display

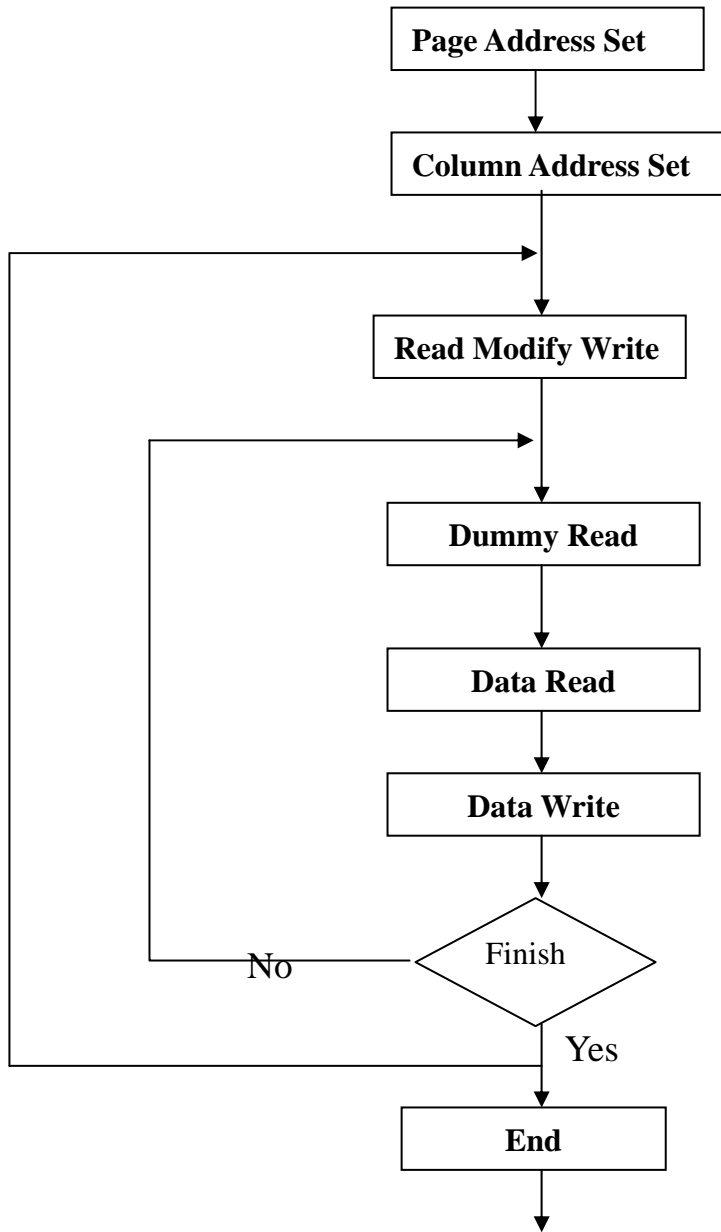

(13) End

This instruction release the Read Modify Write mode and the column address back to the address where the Read Modify write mode setting.

	A0	R/W	D7	D6	D5	D4	D3	D2	D1	D0
Code	0	0	1	1	1	0	1	1	1	0

(14) Reset

This instruction executes the following initialization.

Initialization

- 1) Set the first line the Display Start Line Register.
- 2) Set the page 3 in the page Register.

In this time, there are no influence to the Display Data RAM.

	A0	R/W	D7	D6	D5	D4	D3	D2	D1	D0
Code	0	0	1	1	1	0	0	0	0	0

(Note) The initialization when the power turns on can no be executed by Reset instruction.

(15) Power save (Dual Command)

When both of Display Off and static Drive On are executed, the internal put on the power save mode and the current consumption is reduced as same as stand by current.

The internal status in this mode are as follows;

- 1) Stop the LCD driving . Segment and Common drivers output Vdd level.
- 2) Stop the oscillation or inhibit the external clock input.
- 3) Keeping the display data and operating mode.

The power save mode is released by Display on or static drive off instruction.

12. OPTICAL CHARACTERISTICS:

ITEM	SYMBOL	CONDITION	MIN.	TYP.	MAX.	UNIT	REF.
Contrast	CR	25°C, Vdd=5V, $\theta = 0, \phi = 0$	--	4	--		(2)
Rise Time	Tr	25°C, Vdd=5V, $\theta = 0, \phi = 0$	--	160	240	ms	(3)
Fall Time	Tf	25°C, Vdd=5V, $\theta = 0, \phi = 0$	--	100	150	ms	(3)
Viewing Angle	$\theta 1 - \theta 2$	25°C	70	--	90	DEG	(1)
	$\phi 1, \phi 2$		-40	--	40		

(1)Definition of viewing Angle:

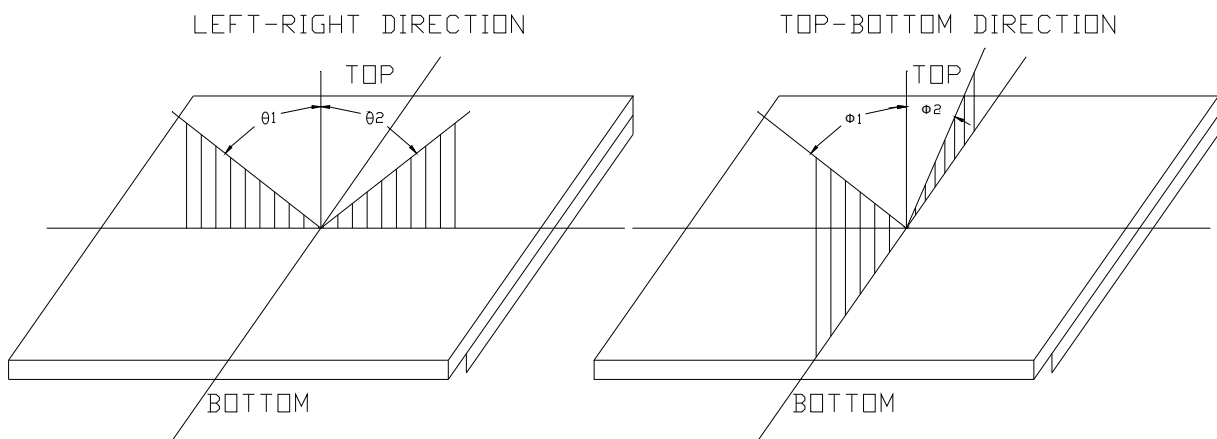

(2)Definition of Contrast Ratio:

$$\text{Contrast Ratio} = \frac{\text{Brightness of non-selected condition}}{\text{Brightness of selected condition}}$$

Test condition: standard A light source

(3)Response Time:

Response time is measured as the shortest period of possible between the change in

state of an LCD segments as demonstrated below:

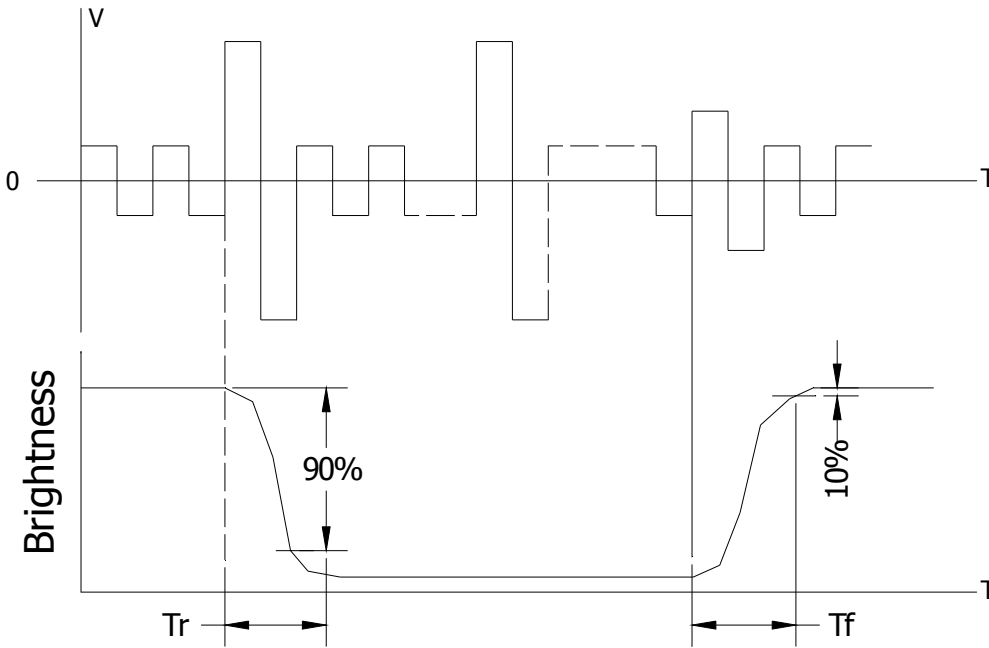

13. POWER SUPPLY SCHEMATICS

For Single Source

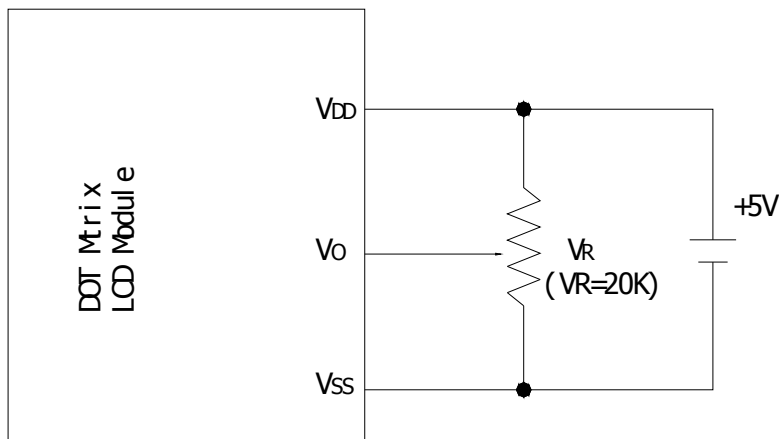

11. APPLICATION EXAMPLE

(1) Application Circuit

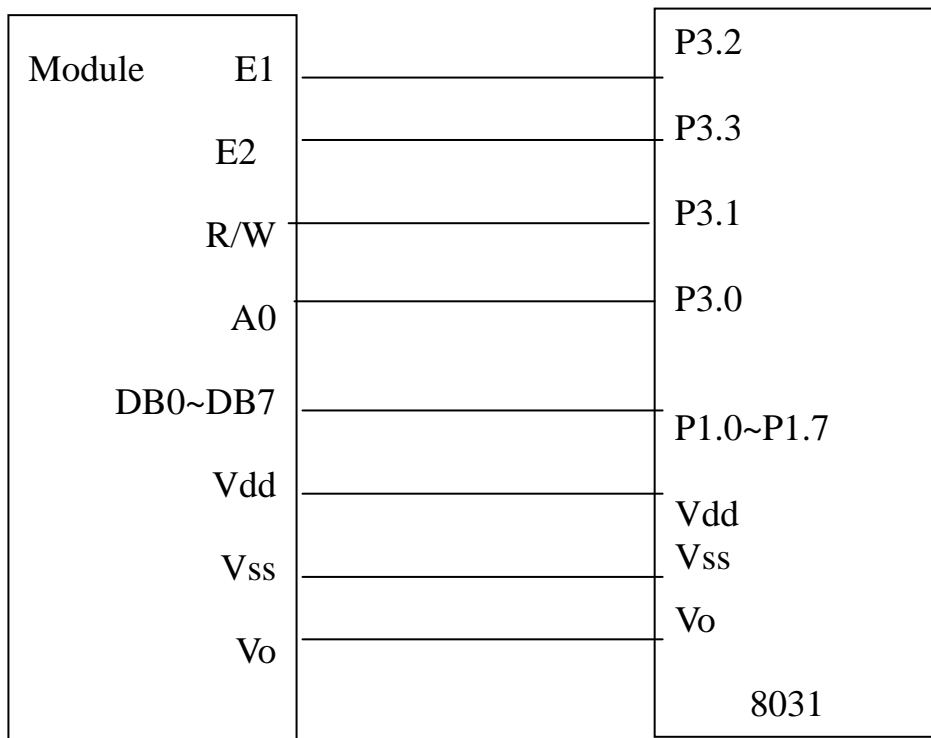

(2) Application Flowchart

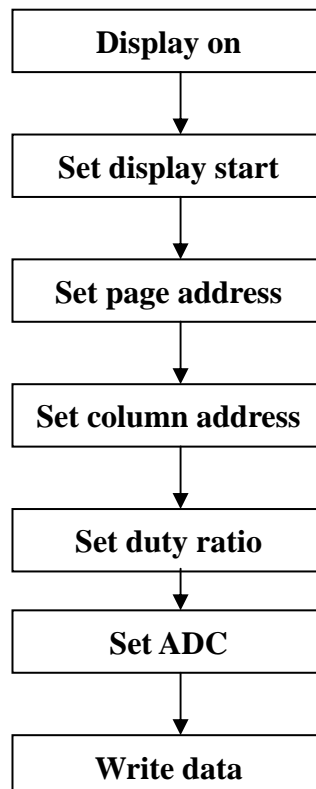

13. PRECAUTION FOR USING LCM

1. LIQUID CRYSTAL DISPLAY (LCD)

LCD is made up of glass, organic sealant, organic fluid, and polymer based polarizers. The following precautions should be taken when handling,

- (1). Keep the temperature within range of use and storage. Excessive temperature and humidity could cause polarization degradation, polarizer peel off or bubble.
- (2). Do not contact the exposed polarizers with anything harder than an HB pencil lead. To clean dust off the display surface. Wipe gently with cotton. Chamois or other soft material soaked in petroleum benzene.
- (3). Wipe off saliva or water drops immediately. Contact with water over a long period of time may cause polarizer deformation or color fading, while an active LCD with water condensation on its surface will cause corrosion of ITO electrodes.
- (4). Glass can be easily chipped or cracked from rough handling, especially at corners and edges.
- (5). Do not drive LCD with DC voltage.

2. Liquid Crystal Display Modules

2.1 Mechanical Considerations

LCM are assembled and adjusted with a high degree of precision. Avoid excessive shocks and do not make any alterations or modifications. The following should be noted.

- (1). Do not tamper in any way with the tabs on the metal frame.
- (2). Do not modify the PCB by drilling extra holes, changing its outline, moving its components or modifying its pattern.
- (3). Do not touch the elastomer connector, especially insert an backlight panel (for example, EL).
- (4). When mounting a LCM make sure that the PCB is not under any stress such as bending or twisting. Elastomer contacts are very delicate and missing pixels could result from slight dislocation of any of the elements.
- (5). Avoid pressing on the metal bezel, otherwise the elastomer connector could be deformed and lose contact, resulting in missing pixels.

2.2. Static Electricity

LCM contains CMOS LSI's and the same precaution for such devices should apply, namely

- (1). The operator should be grounded whenever he/she comes into contact with the module. Never touch any of the conductive parts such as the LSI pads, the copper leads on the PCB and the interface terminals with any parts of the human body.
- (2). The modules should be kept in antistatic bags or other containers resistant to static for storage.
- (3). Only properly grounded soldering irons should be used.
- (4). If an electric screwdriver is used, it should be well grounded and shielded from commutator sparks.
- (5). The normal static prevention measures should be observed for work clothes and working benches; for the latter conductive (rubber) mat is recommended.
- (6). Since dry air is inductive to static, a relative humidity of 50-60% is recommended.

2.3. Soldering

- (1). Solder only to the I/O terminals.
- (2). Use only soldering irons with proper grounding and no leakage.
- (3). Soldering temperature: $280\text{ }^{\circ}\text{C} \pm 10^{\circ}\text{C}$
- (4). Soldering time: 3 to 4 sec.
- (5). Use eutectic solder with resin flux fill.
- (6). If flux is used, the LCD surface should be covered to avoid flux spatters. Flux residue should be removed afterwards.

2.4. Operation

- (1). The viewing angle can be adjusted by varying the LCD driving voltage V_0 .
- (2). Driving voltage should be kept within specified range; excess voltage shortens display life.
- (3). Response time increases with decrease in temperature.

- (4). Display may turn black or dark blue at temperatures above its operational range; this is (however not pressing on the viewing area) may cause the segments to appear “fractured”.
- (5). Mechanical disturbance during operation (such as pressing on the viewing area) may cause the segments to appear “fractured”.

2.5. Storage

If any fluid leaks out of a damaged glass cell, wash off any human part that comes into contact with soap and water. Never swallow the fluid. The toxicity is extremely low but caution should be exercised at all the time.

2.6. Limited Warranty

Unless otherwise agreed between SANTECH and customer, SANTECH will repair or repair any of its LCD and LCM, which is found to be defective electrically and visually when inspected in accordance with SANTECH acceptance standards, for a period on one year from data of shipment. Confirmation of such date shall be based on freight documents. The warranty liability of SANTECH is limited to repair and/or replacement on the terms set forth above. SANTECH will not responsible for any subsequent or consequential events.