

SPECIFICATION FOR APPROVAL

**Product Type: Graphic Type STN Dot Matrix
LCD Module**

Part No.: SD-G24064B-YFDN-DYWP

Customer: _____

Customer Part No.: _____

Date: _____

APPROVED SIGNATURES

SANTECH	Customer

SANTECH DISPLAY CO.,LTD

- 1. REVISION RECORD**
- 2. GENERAL SPECIFICATION**
- 3. OUTLINE DEMENSION:**
- 4. BLOCK DIAGRAM**
- 5. ABSOLUTE MAXIMUM RATINGS**
- 6. ELECTRICAL CHARACTERISTICS**
- 7. ABSOLUTE MAXIMUM RATINGS FOR LED BACKLIGHT**
- 8. PIN ASSIGNMENT**
- 9. MPU INTERFACE**
- 10. FLOWCHART OF COMMUNICATIONS WITH MPU**
- 11. DESCRIPTION OF COMMAND**
- 12. OPTICAL CHARACTERISTICS**
- 13. POWER SUPPLY SCHEMATICS**
- 14. APPLICATION EXAMPLE**
- 15. PRECAUTION FOR USING LCM**

1 . REVISION RECORD

REV	DATA	PAGES	DESCRIPTION

2. GENERAL SPECIFICATION

240×64 dots display

Toshiba LCD controller: T6963C

Interface with 8-bit MPU

Display specification

Display dot: 240×64

Display type: STN(Y/G)

Display color-Display background color: Black-YELLOW/GREEN

Polarizer mode: positive; Transflective

Viewing angle: 6:00

Display duty: 1/128

Display bias: 1/12

Selectable character font: 6X8 or 8X8

Memory and External Memory:

A standard 128-word character generator ROM

8KB external display RAM(static RAM)

Mechanical characteristics (Unit: mm)

External dimension: 180.0X65X14.0

View area: 155.0X39.0

Dot size: 0.49X0.49

Dot pitch: 0.53X0.53

Weight: g

Power: +5V

3. OUTLINE DEMENSION:

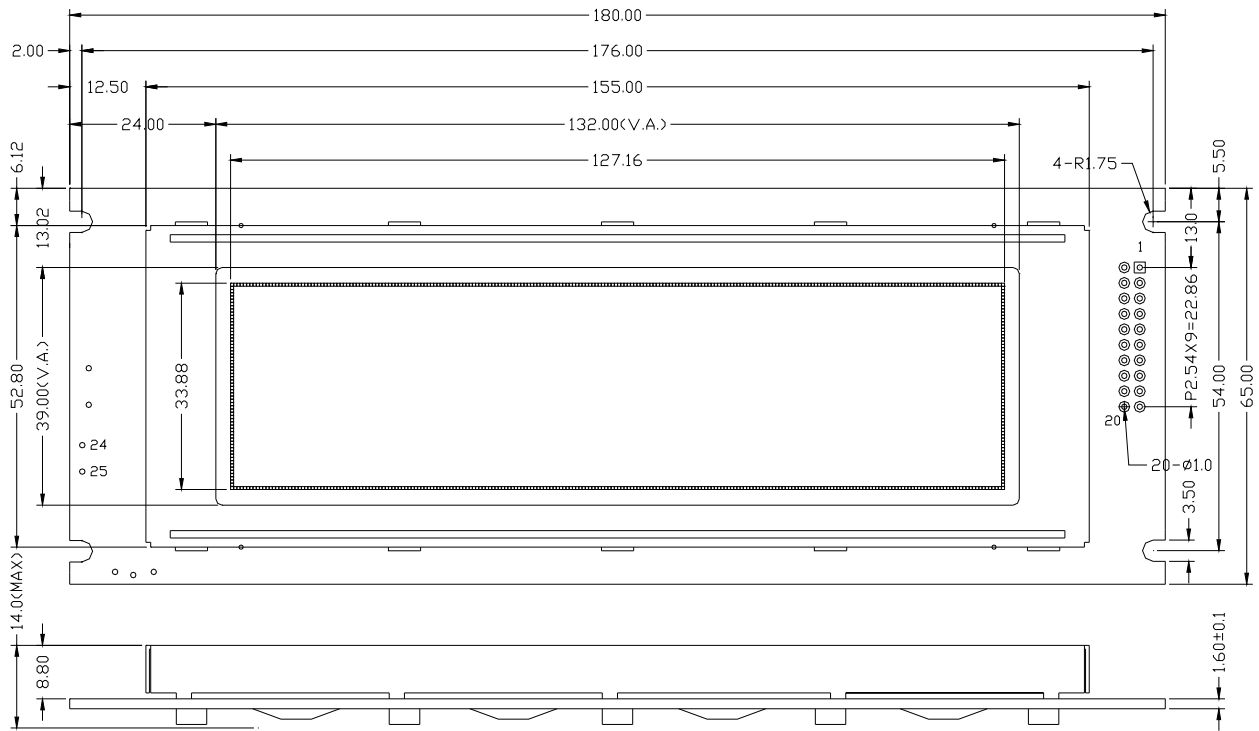

4. BLOCK DIAGRAM:

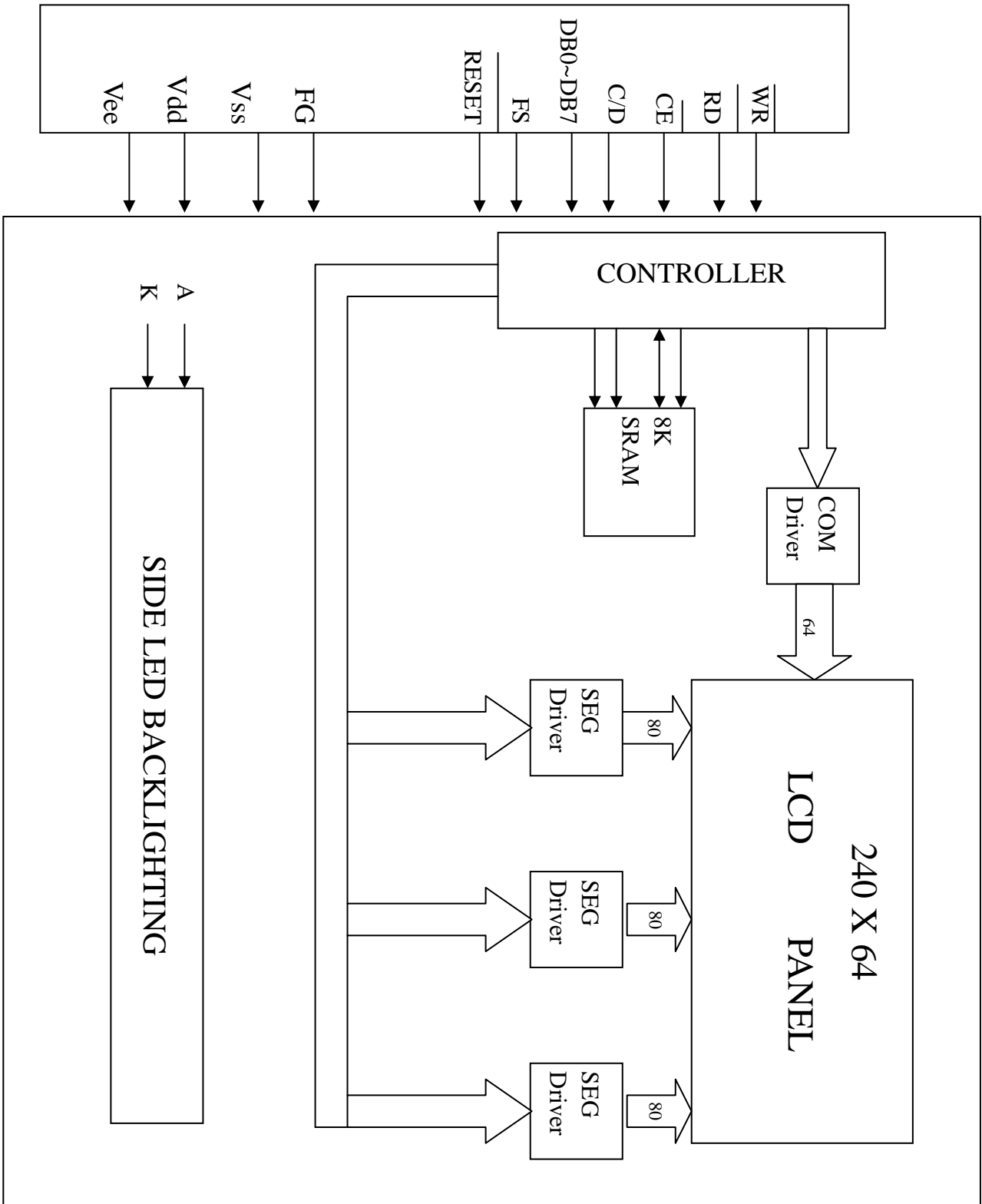

5. Absolute Maximum Ratings

Item	Symbol	Condition	Standard Value		Unit
			Min	Max	
Supply voltage for logic	Vdd	Ta=25 ⁰ C	-0.3	7.0	V
Supply voltage for LCD	Vo		Vdd-10.0	Vdd+0.3	V
Input Voltage	Vi		-0.3	Vdd+0.3	V
Operating Temp(T)	Top	-	0	50	⁰ C
Storage Temp(T)	Tstg	-	-10	60	⁰ C

6. ELECTRICAL SPECIFICATIONS (Ta=25⁰C,Vdd=5.0V)

Item	Symbol	Condition	Standard Value			Unit
			Min	Type	Max	
Supply voltage for logic	Vdd-Vss	-	4.5	5.0	5.5	V
Supply Current for logic	Idd	Vdd=5.0	-	9.5	-	mA
Driving Current for LCD	Iee	Vee=-7.8	-	4.6	-	mA
Driving Voltage for LCD	Top	25 ⁰ C -	-	12.0	-	V
Input Voltage “H” level	Tstg	H	0.7Vdd	-	Vdd	V
Input Voltage “L” level	HTop	L	0	-	0.8	V

7. Absolute Maximum Ratings for LED Backlight

Parameter	Symbol	Test condition	Min	Type	Max	Unit
LED Forward Consumption Current	I _f	Ta=25 ⁰ C Vf=5.0V	-	720	1080	mA
LED Allowable Dissipation	P _d		-	3024	4536	mW

8. Pin assignment

Pin NO.	Symbol	Function		Remark
1	FG	Power Supply	Frame Ground	
2	Vss		0V	
3	Vdd		+5V	
4	Vo		For LCD	Variable
5	/WR	Data Write		
6	/RD	Data Read		
7	/CE	Chip Enable		
8	C/D	Command/Data Select		
9	NC	No Connect		
10	/RST	Reset Signal		
11-18	DB0-DB7	Data Bit 0-7		
19	FS	Font Select		
20	Vee	Negative Power Output		
24	K	Cathode of LED Unit		
25	A	Anode of LED Unit		

9. MPU Interface

ITEM	SYMBOL	MIN	MAX	UNIT
C/D Set-up Time	tCDS	100	-	ns
C/D Hold Time	tCDH	10	-	ns
CE, RD, WR Pulse Width	tCE, tRD, tWR	80	-	ns
Data Set-up Time	tDS	80	-	ns
Data Hold Time	tDH	40	-	ns
Access, Time	tACC	-	150	ns
Output Hold Time	tOH	10	50	ns

THST CONDITIONS (Unless otherwise noted, $V_{dd}=5.0V \pm 10\%$, $V_{ss}=0V$, $T_a=-20$ to $75^\circ C$)

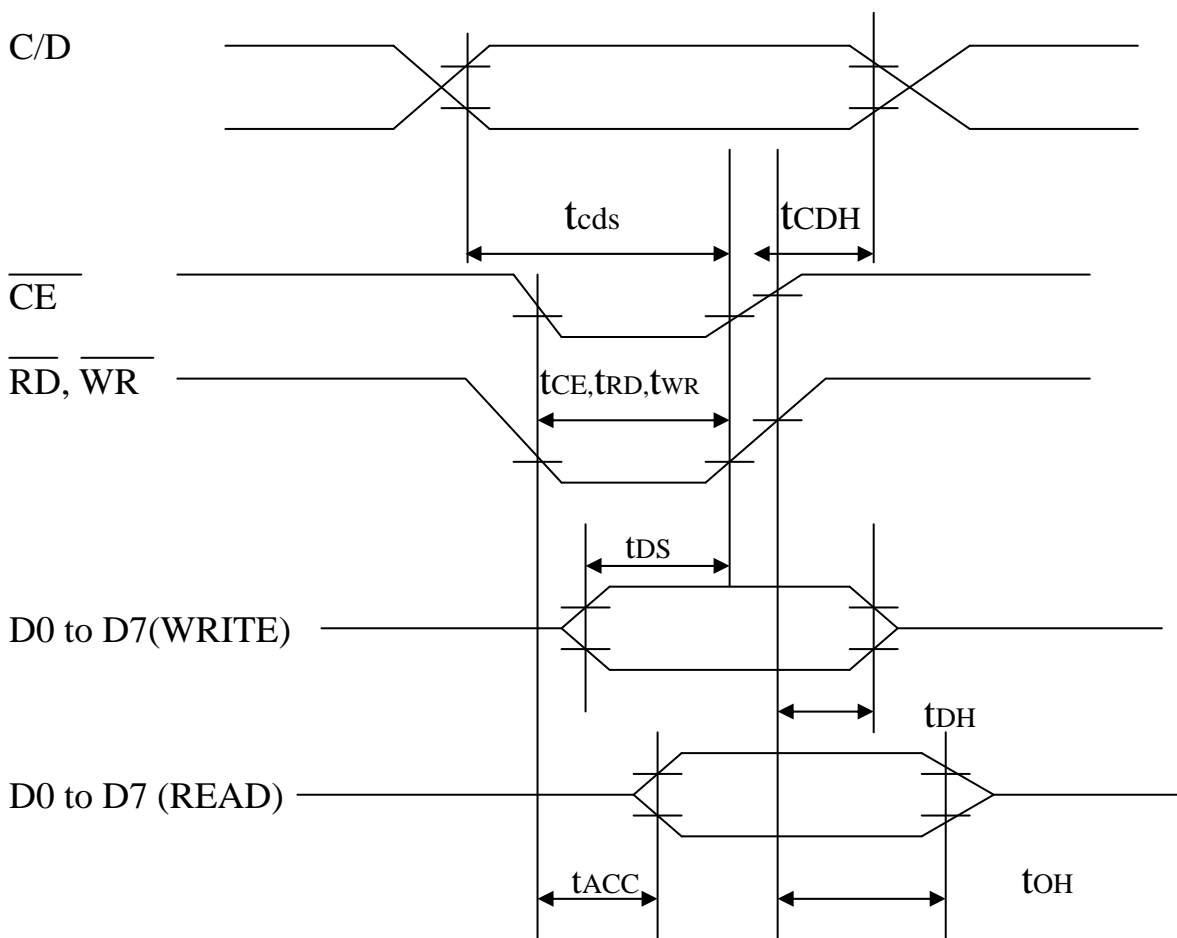

10.Flowchart of communications with MPU

Status Word

MSB				LSB			
STA7	STA6	STA5	STA4	STA3	STA2	STA1	STA0
D7	D6	D5	D4	D3	D2	D1	D0

STA0	Check command execution capability	0:Disable 1:Enable
STA1	Check data read/write capability	0:Disable 1:Enable
STA2	Check Auto mode data read capability	0:Disable 1:Enable
STA3	Check Auto mode data write capability	0:Disable 1:Enable
STA4	Not used	
STA5	Check controller operation capability	0:Disable 1:Enable
STA6	Error flag. Used for Screen Peek and Screen Copy commands	0:No error 1:Enable
STA7	Check the blink condition	0:Disiplayoff 1:Normal display

Note1: A status check must be performed before data is read or written.

Note2: It is necessary to check STA0 and STA1 at the same time.

There is a possibility of erroneous operation due to a hardware interrupt.

Note3: For most modes STA0/STA1 are used as a staus check.

Note4: STA2 and STA3 are valid in Auto mode;STA0 and STA1 are invalid.

Setting Data

a) The case of 1 data

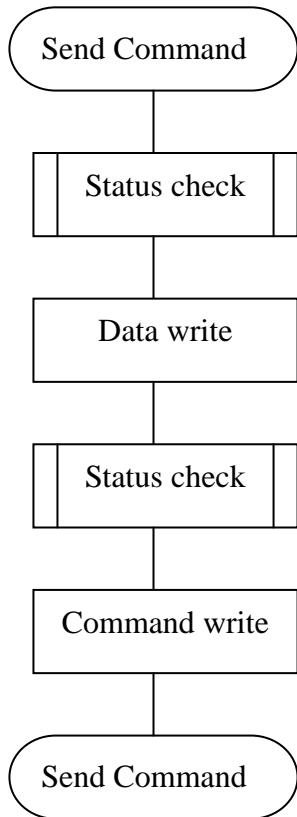

b) The case of 2 data

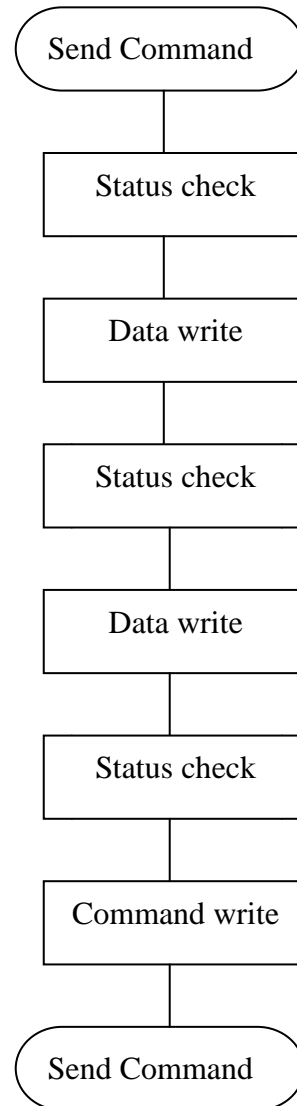

11.COMMAND DEFINITIONS

COMMAND	CODE	D1	D2	FUNCTION
REGISTERS SETTING	00100001	X address	Y address	Set Cursor Pointer
	00100010	Data	00H	Set Offset Register
	00100100	Low address	High address	Set Address Pointer
SET CONTROL WORD	01000000	Low address	High address	Set Test Home Address
	01000001	Columns	00H	Set Text Area
	01000010	Low address	High address	Set Graphic Home Address
	01000011	Columns	00H	Set Graphic Area

Command Definitions

COMMAND	CODE	D1	D2	FUNCTION
MODE SET	1000X000	-	-	OR mode
	1000X001	-	-	EXOR mode
	1000X011	-	-	AND mode
	1000X100	-	-	Text Attribute mode
	10000XXX	-	-	Internal CG ROM mode
	10001XXX	-	-	External CG RAM mode
DISPLAY MODE	10010000	-	--	Display off
	1001XX10	--	-	Cursor on, blink off
	1001XX11	-	-	Cursor on, blink on
	100101XX	-	-	Text on, graphic off
	100110XX	-	-	Text off, graphic on
	100111XX	-	-	Text on, graphic on
CURSOR PATTERN SELECT	10100000	-	-	1-line cursor
	10100001	-	-	2-line cursor
	10100010	-	-	3-line cursor
	10100011	-	-	4-line cursor
	10100100	-	-	5-line cursor
	10100101	-	-	6-line cursor
	10100110	-	-	7-line cursor
	10100111	-	-	8-line cursor
DATA AUTO READ/WRITE	10110000	-	-	Set Data Auto Write
	10110001	-	-	Set Data Auto Read
	10110010	-	-	Auto Reset
DATA READ/WRITE	11000000	Data	-	Data Write and Increment ADP
	11000001	-	-	Data Read and Increment ADP
	11000010	Data	-	Data Write and Decrement ADP
	11000011	-	-	Data Read and Decrement ADP
	11000100	Data	-	Data Write and Non-variable ADP
	11000101	-	-	Data Read and Non-variable ADP
SCREEN PEEK	11100000	-	-	Screen Peek
SCREEN COPY	11101000	-	-	SCREEN Copy
	11110XXX	-	-	Bit Reset
	11111XXX	-	-	Bit Set
	1111X000	-	-	Bit 0 (LSB)
	1111X001	-	-	Bit1
	1111X010	-	-	Bit2
	1111X011	--	-	Bit3
	1111X100	-	-	Bit4
	1111X101	-	-	Bit5

Note: First set the data, then set the command.

● **Description of Command**

Setting Registers

(1) Set Cursor Pointer

The position of the cursor is specified by X ADRS and Y ADRS. The cursor position Can only be moved by this command. Data read/write from the MPU never changes the cursor pointer.

X ADRS:00H to 4FH(lower 7 bits are valid); Y ADRS:00H to 1FH(lower 5 bits are valid)

a) Single-Scan

X ADRS 00 to 4FH

Y ADRS 00H to 0FH

b) Dual-Scan

X ADRS 00H to 4FH

Y ADRS 00H to 0FH Upper screen
Y ADRS10H to 1FH Lower screen

(2) Set Offset Register

The offset register is used to determine the external character generator RAM area.

MSB

LSB

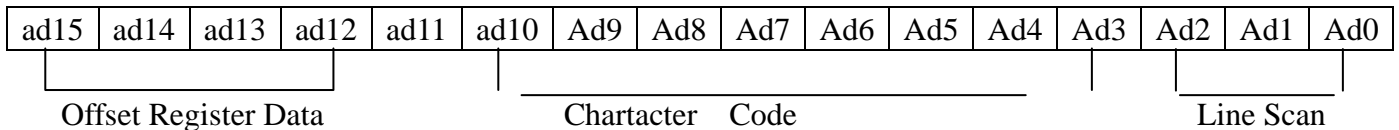

The senior five bits define the start address in external memory of the CG RAM area. The next eight bits represent the character code of the character. In internal CG ROM mode, Character codes 00H to 7FH represent the predefined “internal” CG ROM Characters, and codes 80H to FFH represent the user’s own “external” characters. In external CG RAM mode, all 256 codes from 00H to FFH can be used to represent the user’s own characters. The three least significant bits indicate one of the eight rows of eight dots that define the character’s shape. The relationship between display RAM address and offset register

Offset register data	CGRAM hex. Address(start to end)
00000	0000 to 07FFH
00001	0800 to 0FFFH
00010	1000 to 17FFH
11100	E 000 to E7FFH
11101	E 800 to EFFFH
11110	F 000 to F7FFH
11111	F 800 to FFFFH

Example:

Offset register	02H	
Character code	80H	
Character generator RAM start address	0001 0100 0000 0000	
	1 4 0 0 H	

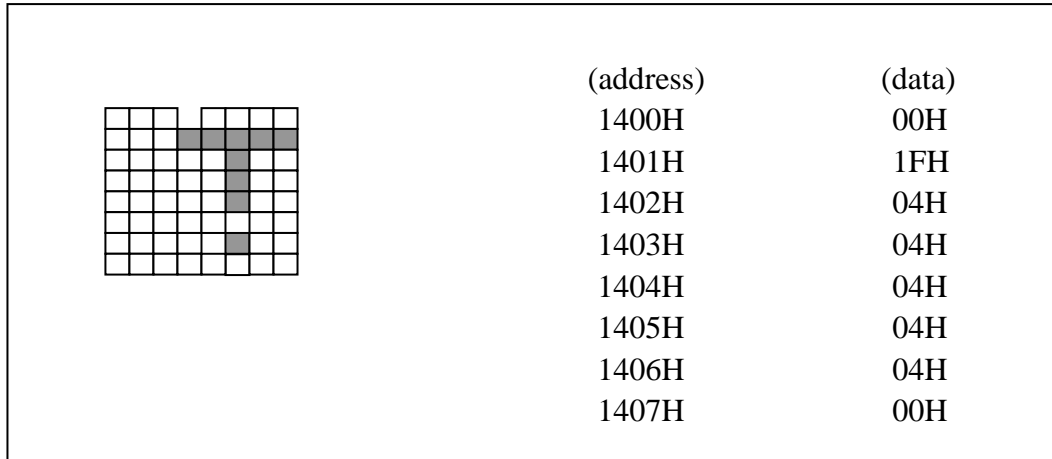

Example 2:

The relationship between display RAM data and display characters:

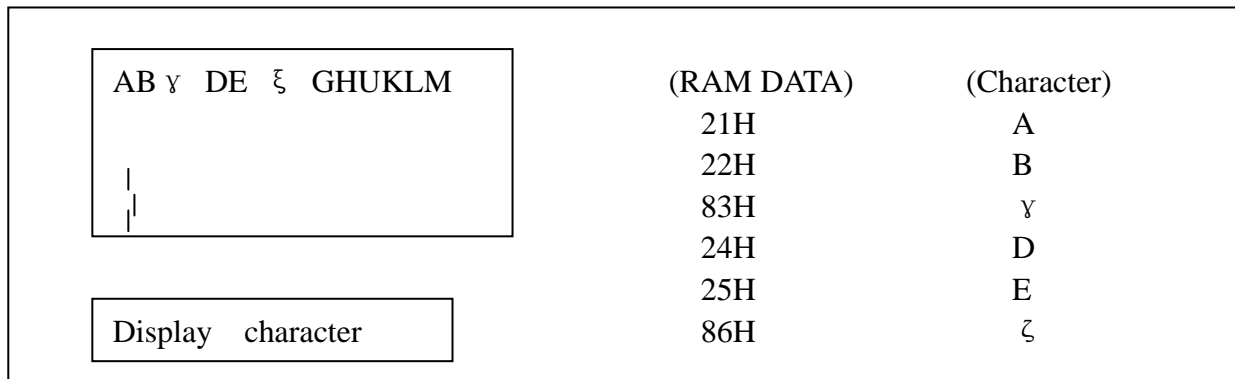

γ and ξ are display by character generator RAM

(3) Set Address Pointer

The Set Address Pointer command is used to indicate the start address for writing to(or reading from) external RAM.

The FI chart for set Address Pointer command

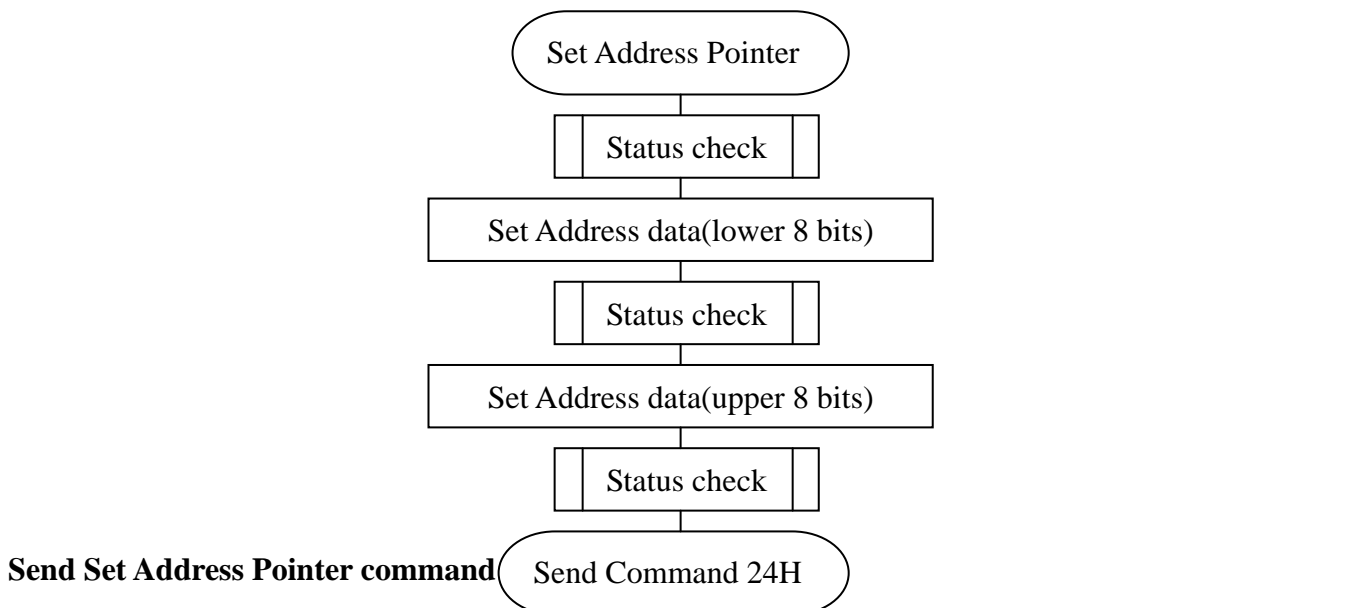

Set Control Word

The home address and column size are defined by this command.

(1) Set Text Home Address

The starting address in the external display RAM for text display is defined by this command.

The text home address indicates the leftmost and uppermost position.

The relationship between external display RAM address and display position.

TH	TH+CL
TH+TA	TH+TA+CL
(TH+TA)+TA	TH+2TA+CL
.....
TH+(N-1)TA	TH+(N-1)TA+CL

TH: Text home address TA: Text area number(columns)

CL: Columns are fixed by hardware(pin-programmable).

Example:

Text home address: 0000H Text area: 0020H
MD2=H, MD3=H: 32 columns DUAL=H, MDS=L, MD0=L,MD1=H: 4lines

0000H	0001H	001EH	001FH
0020H	0021H	003EH	003FH
0040H	0041H	005EH	005FH
0060H	0061H	007EH	007FH

(2) Set Graphic Home Address

The starting address of the external display RAM used for graphic display is defined by this command.

The graphic home address indicates the leftmost and uppermost position. The relationship between external display RAM address and display position.

GH	GH+CL
GH+GA	GH+GA+CL
(GH+GA)+GA	GH+2GA+CL
.....
GH+(N-1)GA	GH+(N-1)GA+CL

GH: Graphic home address GA: Graphic area number (columns)

CL: Columns are fixed by hardware(pin-programmable).

Example:

Graphic home address: 0000H Graphic area: 0020H
MD2=H, MD3=H : 32columns DUAL=H, MDS=L, DM1=H: 21lines

0000H	0001H	001EH	001FH
0020H	0021H	003EH	003FH
0040H	0041H	005EH	005FH
0060H	0061H	007EH	007FH
0080H	0081H	009EH	009FH
00A0H	00A1H	00BEH	00BFH
00C0H	00C1H	00DEH	00DFH
00E0H	00E1H	00FEH	00FFH
0100H	0101H	011EH	011FH

0120H	0121H	013EH	013FH
0140H	0141H	015EH	015FH
0160H	0161H	017EH	017FH
0180H	0181H	019EH	019FH
01A0H	01A1H	01BEH	01BFH
01C0H	01C1H	01DEH	01DFH
01E0H	01E1H	01FEH	01FFH

(3) Set Text Area

This command can be used to define the columns of the test display.

Example:

LCD size: 20 columns, 4lines Text home address: 0000H
 Text area: 0014H MD2=H, MD3=H: 32 columns
 DUAL=H, MDS=L, MD0=L, MD1=H: 4 lines

0000	0001	0013	0014	001F
0014	0015	0027	0028	0033
0028	0029	003C	003C	0047
003C	003D	004F	0050	005B



(4) Set Graphic Area

This command can be used to define the columns of the graphic display.

Example:

LCD size: 20 columns, 21lines Graphic home address :0000H
 Graphic area: 0014H MD2=H, MD3=H: 0014H
 DUAL=H, MDS=L, MD0=H, MD1=H: 2lines

0000	0001	0013	0014	001F
0014	0015	0027	0028	0033
0028	0029	003B	003C	0047
003C	003D	004F	0050	005B
0050	0051	0063	0064	006F
0064	0065	0077	0078	0083
0078	0079	008B	008C	0097
008C	008D	009F	00A0	00AB
00A0	00A1	00B3	00B4	00BF
00B4	00B5	00C7	00C8	00D3
00C8	00C9	00DB	00DC	00E7
00DC	00DD	00EF	00F0	00FD
00F0	00F1	0103	0104	011F
0104	0105	0127	0128	0123
0128	0129	013B	013C	0147
013C	013D	014F	0150	015B



Mode Set

The display mode does not change until the next command is sent. In Internal Character Generator mode, character codes 00H to 7FH are assigned to the built-in character generator RAM. The character codes 80H to FFH are automatically assigned to the external character generator RAM.

Example:(Note: Attribute functions can only be applied to applied to text display, since the attribute data is placed in the graphic RAM area.)

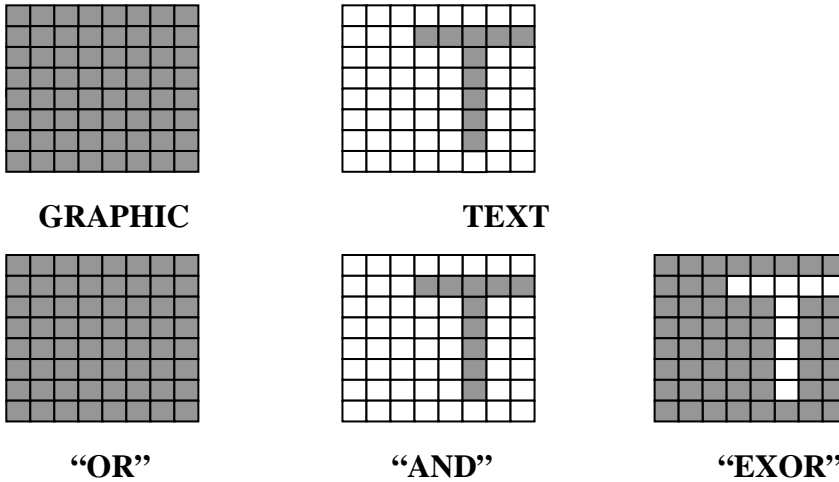

Attribute Function

The attribute operations reverse display, Character blink and inhibit .The attribute data is written into the graphic area which was defined by the Set Control Word command. Only text display is possible in Attribute function mode; graphic display is automatically Disabled. However, the Display Mode command must be used to turn both Text and Graphic on in order for the Attribute function to be available.

Attribute RAM 1byte

X	X	X	X	d3	d2	d1	d0
d3	d2	d1	d0	FUNCTION			
0	0	0	0	Normal display			
0	1	0	1	Reverse display			
0	0	1	1	Inhibit display			
1	0	0	0	Blink of normal display			
1	1	0	1	Blink of reverse display			
1	0	1	1	Blink of inhibit of display			

X: invalid

Display Mode

It is necessary to turn on “Text display” and “Graphic display” in the following cases.

- a) Combination of text/graphic display
- b) Attribute function

Cursor Pattern Select

When cursor display is ON ,this command selects the cursor pattern in the range 1 line to 8 lines. The cursor address is defined by the Cursor Pointer Set command.

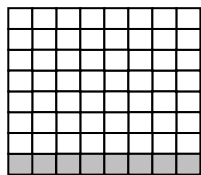

1-line cursor

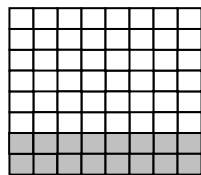

2-line cursor

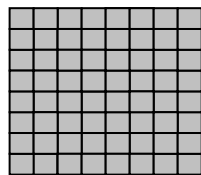

8-line cursor

Data Auto Read /Write

This command is convenient for sending a full screen of data from the external display RAM. After setting Auto mode, a Data Write(or Read)command is need not be sent between each datum. A Data Auto Write(or Read) command must be sent after a Set Address Pointer command. After this command, the address pointer is automatically incremented by 1 after each data. In Auto mode, the LCM cannot accept any other commands. The Auto Rest command must be sent to the LCM after all data has been sent, to clear Auto mode.

Data Read/Write

This command is used for writing data from the MPU to external display RAM, and reading data from external display RAM to the MPU. Data Write/Read should be executed after setting address using Set Address Pointer command. The address pointer can be automatically incremented or decrement using this command.

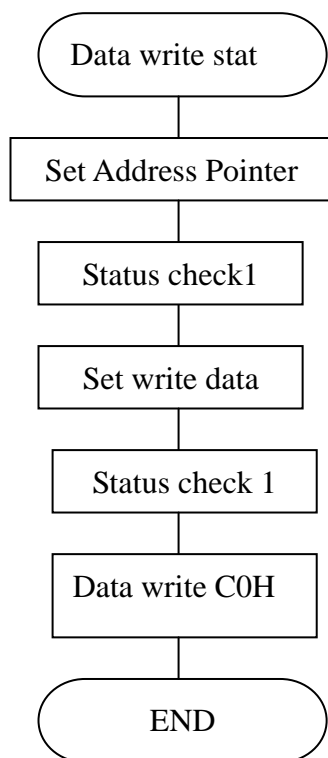

Screen Peek

The command is used to transfer 1 byte of displayed data to the data stack; this byte can then be read from the MPU by data access. The logical combination of text and graphic display data on the LCD

screen can be read by this command.

The status (STA6) should be checked just after the Screen Peek command. If the address determined by the Set Address Pointer command is not in the graphic area, this command is ignored and a status flag (STA6) is set.

Refer to the following flowchart

Note: This command is available when hardware column number and software column number are the same. Hardware column number is related to MD2 and MD3 setting. Software column number is related to Set Text Area and Set Graphic Area command.

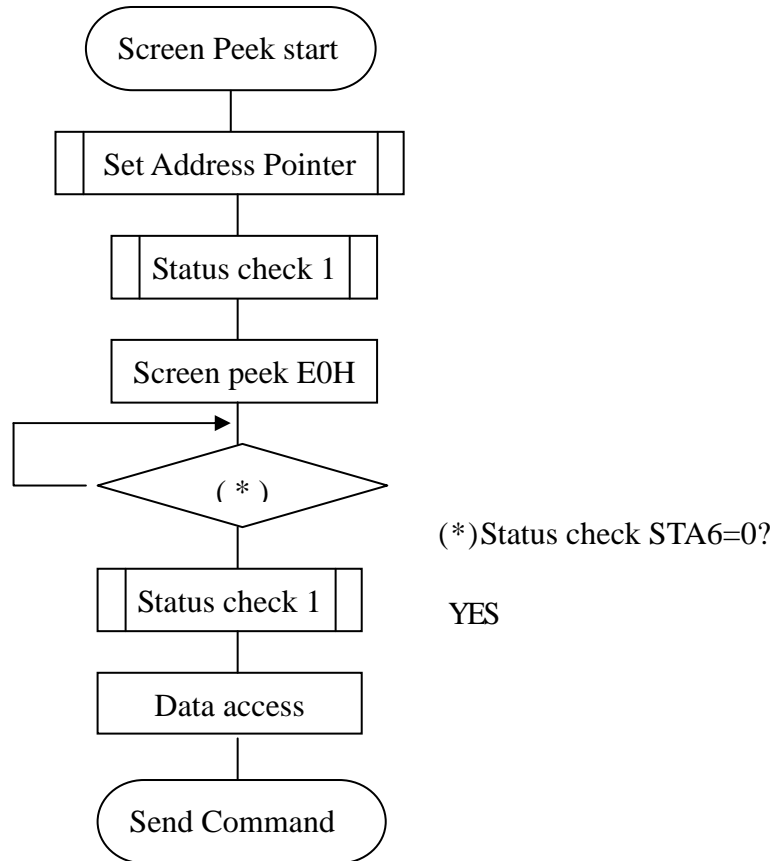

(Note) This command is available when hardware column number and software column number are the same. Hardware column number is related to MD2 and MD3 setting. Software column number is related to Set Text Area and Set Graphic Area command.

Screen Copy

This command copies a single raster line of data to the graphic area. The start point must be set using the Set Address Pointer command.

Refer to the following flowchart:

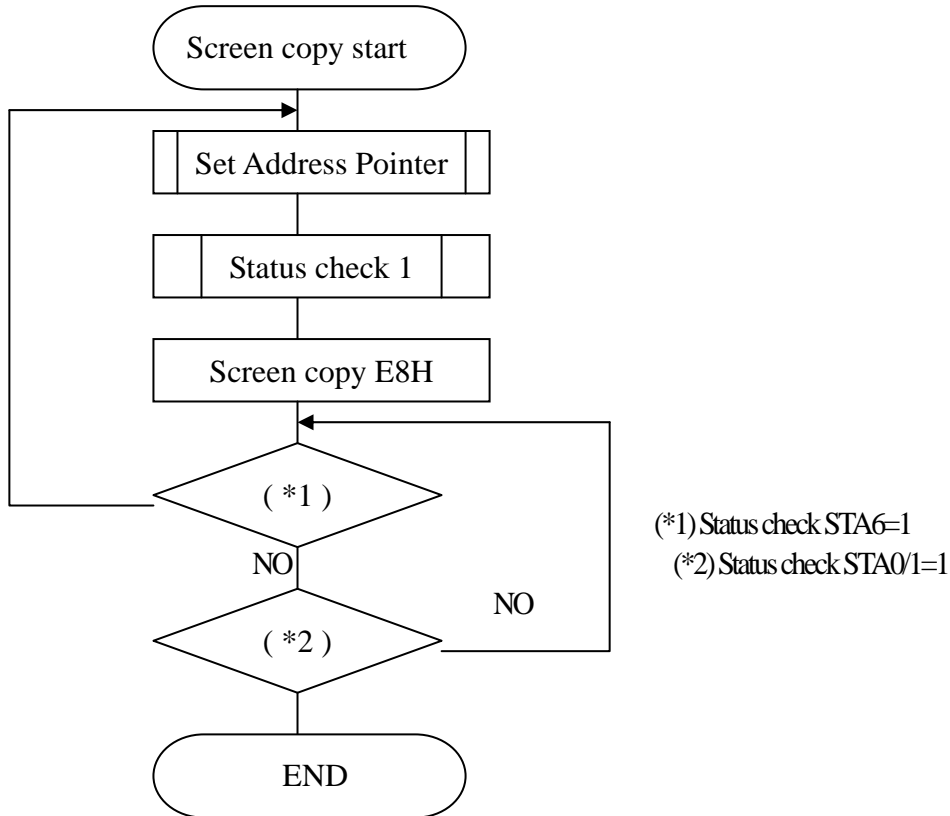

Notel: If the attribute function is being used, this command is not available.(With Attribute data is graphic area data)

Note2: With Dual-Scan, this command cannot be used (because the LCM cannot separate the upper screen data and lower screen data)

Note3: This command is available when hardware column number and software column number are the same.

Bit Set /Reset

This command use to set or reset a bit of the byte specified by the address pointer. Only one bit can be set /rest at a time.

Refer to the following flowchart:

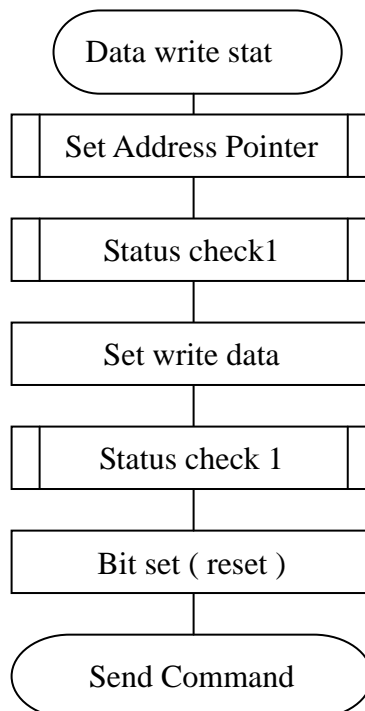

12.OPTICAL CHARACTERISTICS:

ITEM	SYMBOL	CONDITION	MIN.	TYP.	MAX.	UNIT	REF.
Contrast	CR	25°C, Vdd=5V, θ =0, Ø=0	--	12	--		(2)
Rise Time	Tr	25°C, Vdd=5V, θ =0, Ø=0	--	160	240	ms	(3)
Fall Time	Tf	25°C, Vdd=5V, θ =0, Ø=0	--	100	150	ms	(3)
Viewing Angle	θ 1- θ 2	25°C	--	--	60	DEG	(1)
	Ø1, Ø2		-40	--	40		

(1)Definition of viewing Angle:

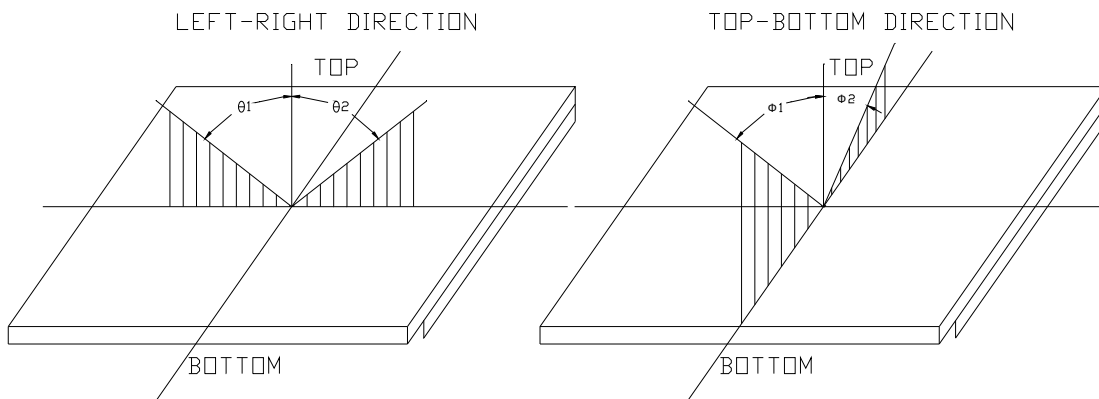

(2)Definition of Contrast Ratio:

$$\text{Contrast Ratio} = \frac{\text{Brightness of non-selected condition}}{\text{Brightness of selected condition}}$$

Test condition: standard A light source

(3)Response Time:

Response time is measured as the shortest period of possible between the change in state of an LCD segments as demonstrated below:

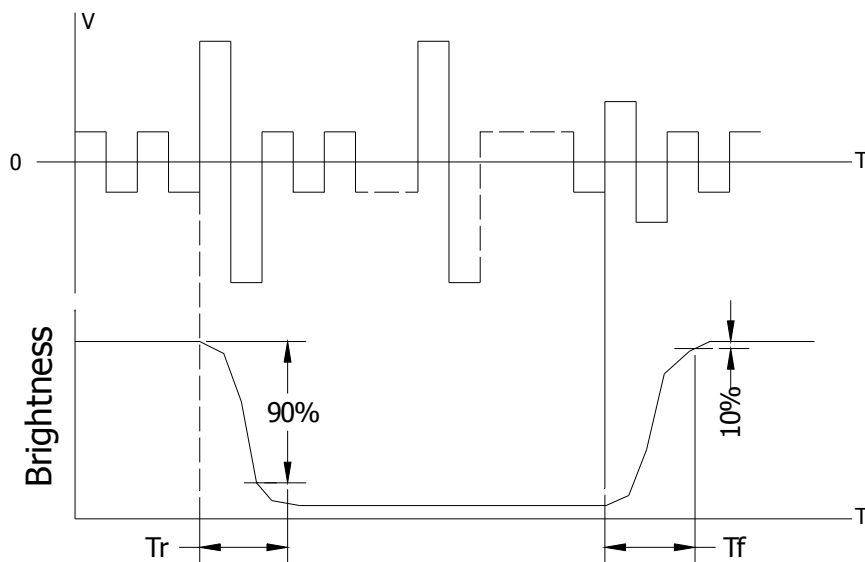

13. POWER SUPPLY SCHEMATICS

For Double Source

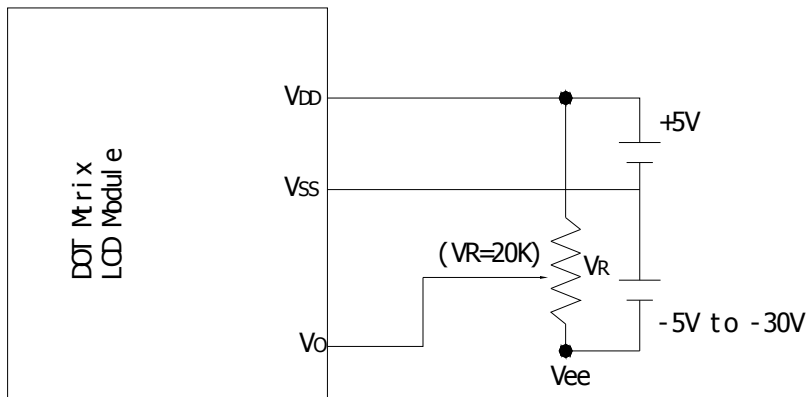

14. APPLICATION EXAMPLE

Application Circuit

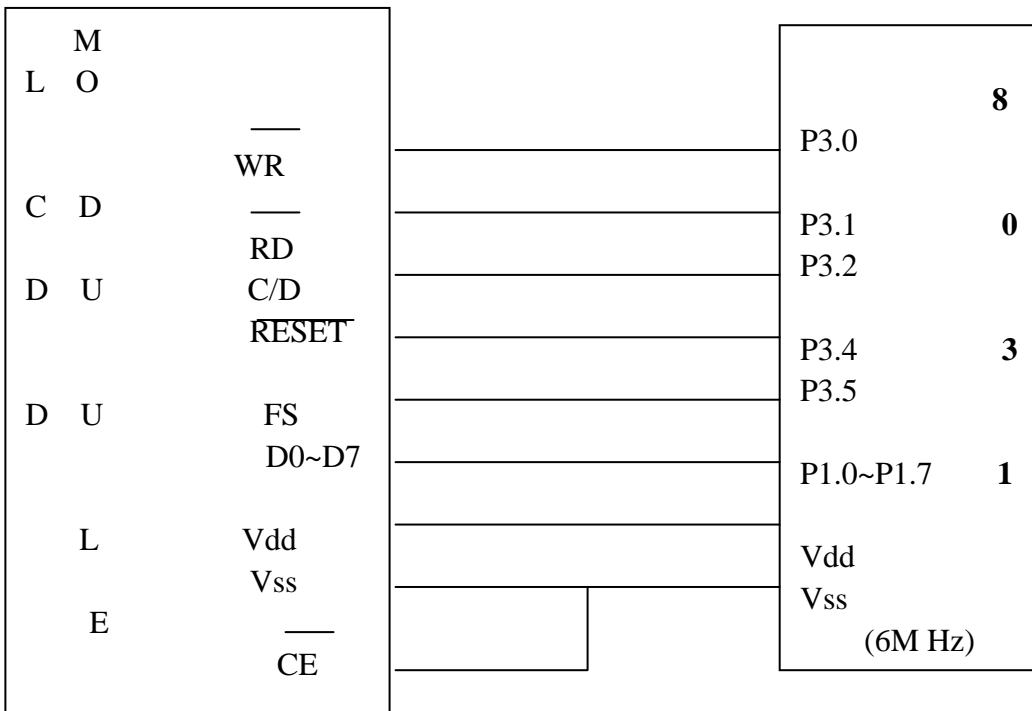

15. PRECAUTION FOR USING LCM

1. LIQUID CRYSTAL DISPLAY (LCD)

LCD is made up of glass, organic sealant, organic fluid, and polymer based polarizers. The following precautions should be taken when handling,

- (1). Keep the temperature within range of use and storage. Excessive temperature and humidity could cause polarization degradation, polarizer peel off or bubble.
- (2). Do not contact the exposed polarizers with anything harder than an HB pencil lead. To clean dust off the display surface. Wipe gently with cotton. Chamois or other soft material soaked in petroleum benzene.
- (3). Wipe off saliva or water drops immediately. Contact with water over a long period of time may cause polarizer deformation or color fading, while an active LCD with water condensation on its surface will cause corrosion of ITO electrodes.
- (4). Glass can be easily chipped or cracked from rough handling, especially at corners and edges.
- (5). Do not drive LCD with DC voltage.

2. Liquid Crystal Display Modules

2.1 Mechanical Considerations

LCM are assembled and adjusted with a high degree of precision. Avoid excessive shocks and do not make any alterations or modifications. The following should be noted.

- (1). Do not tamper in any way with the tabs on the metal frame.
- (2). Do not modify the PCB by drilling extra holes, changing its outline, moving its components or modifying its pattern.
- (3). Do not touch the elastomer connector, especially insert an backlight panel (for example, EL).
- (4). When mounting a LCM make sure that the PCB is not under any stress such as bending or twisting. Elastomer contacts are very delicate and missing pixels could result from slight dislocation of any of the elements.
- (5). Avoid pressing on the metal bezel, otherwise the elastomer connector could be deformed and lose contact, resulting in missing pixels.

2.2. Static Electricity

LCM contains CMOS LSI's and the same precaution for such devices should apply, namely

- (1). The operator should be grounded whenever he/she comes into contact with the module. Never touch any of the conductive parts such as the LSI pads, the copper leads on the PCB and the interface terminals with any parts of the human body.
- (2). The modules should be kept in antistatic bags or other containers resistant to static for storage.
- (3). Only properly grounded soldering irons should be used.
- (4). If an electric screwdriver is used, it should be well grounded and shielded from commutator sparks.
- (5). The normal static prevention measures should be observed for work clothes and working benches; for the latter conductive (rubber) mat is recommended.
- (6). Since dry air is inductive to static, a relative humidity of 50-60% is recommended.

2.3. Soldering

- (1). Solder only to the I/O terminals.
- (2). Use only soldering irons with proper grounding and no leakage.
- (3). Soldering temperature: $280\text{ }^{\circ}\text{C} \pm 10^{\circ}\text{C}$
- (4). Soldering time: 3 to 4 sec.
- (5). Use eutectic solder with resin flux fill.
- (6). If flux is used, the LCD surface should be covered to avoid flux spatters. Flux residue should be removed afterwards.

2.4. Operation

- (1). The viewing angle can be adjusted by varying the LCD driving voltage V_0 .
- (2). Driving voltage should be kept within specified range; excess voltage shortens display life.

- (3). Response time increases with decrease in temperature.
- (4). Display may turn black or dark blue at temperatures above its operational range; this is (however not pressing on the viewing area) may cause the segments to appear “fractured”.
- (5). Mechanical disturbance during operation (such as pressing on the viewing area) may cause the segments to appear “fractured”.

2.5. Storage

If any fluid leaks out of a damaged glass cell, wash off any human part that comes into contact with soap and water. Never swallow the fluid. The toxicity is extremely low but caution should be exercised at all the time.

2.6. Limited Warranty

Unless otherwise agreed between SANTECH and customer, SANTECH will repair or repair any of its LCD and IC, which is found to be defective electrically and visually when inspected in accordance with SANTECH acceptance standards, for a period on one year from data of shipment. Confirmation of such date shall be based on freight documents. The warranty liability of SANTECH is limited to repair and/or replacement on the terms set forth above. SANTECH will not responsible for any subsequent or consequential events.